



Agilent 6224/6230 Series TOF LC/MS System

Maintenance Guide

**Research Use Only. Not for use in Diagnostic
Procedures.**



Agilent Technologies

Notices

© Agilent Technologies, Inc. 2009

No part of this manual may be reproduced in any form or by any means (including electronic storage and retrieval or translation into a foreign language) without prior agreement and written consent from Agilent Technologies, Inc. as governed by United States and international copyright laws.

Manual Part Number

G2597-90005

Edition

First Edition, March 2009

Printed in USA

Agilent Technologies, Inc.
5301 Stevens Creek Blvd.
Santa Clara, CA 95051

Warranty

The material contained in this document is provided “as is,” and is subject to being changed, without notice, in future editions. Further, to the maximum extent permitted by applicable law, Agilent disclaims all warranties, either express or implied, with regard to this manual and any information contained herein, including but not limited to the implied warranties of merchantability and fitness for a particular purpose. Agilent shall not be liable for errors or for incidental or consequential damages in connection with the furnishing, use, or performance of this document or of any information contained herein. Should Agilent and the user have a separate written agreement with warranty terms covering the material in this document that conflict with these terms, the warranty terms in the separate agreement shall control.

Technology Licenses

The hardware and/or software described in this document are furnished under a license and may be used or copied only in accordance with the terms of such license.

Restricted Rights Legend

U.S. Government Restricted Rights. Software and technical data rights granted to the federal government include only those rights customarily provided to end user customers. Agilent provides this customary commercial license in Software and technical data pursuant to FAR 12.211 (Technical Data) and 12.212 (Computer Software) and, for the Department of Defense, DFARS 252.227-7015 (Technical Data - Commercial Items) and DFARS 227.7202-3 (Rights in Commercial Computer Software or Computer Software Documentation). Safety Notices

CAUTION

A **CAUTION** notice denotes a hazard. It calls attention to an operating procedure, practice, or the like that, if not correctly performed or adhered to, could result in damage to the product or loss of important data. Do not proceed beyond a **CAUTION** notice until the indicated conditions are fully understood and met.

WARNING

A **WARNING** notice denotes a hazard. It calls attention to an operating procedure, practice, or the like that, if not correctly performed or adhered to, could result in personal injury or death. Do not proceed beyond a **WARNING** notice until the indicated conditions are fully understood and met.

Contents

1 Basic Operation 7

Starting and Shutting Down 10

To start the system in Standby mode 12

To change from Standby to On 15

To change from On to Standby 16

To shut down the instrument 17

Changing Ion Sources 19

To remove an electrospray source 19

To remove the ESI with Agilent Jet Stream Technology 20

To remove a multimode source 20

To remove an APCI or APPI source 21

To remove a nano ESI source 22

To remove a dual nano ESI source 23

To install an electrospray source 24

To install an APCI source 25

To install an APPI source 26

To install a nano ESI, dual nano ESI or multimode source or HPLC-Chip/MS interface 26

To install the Agilent Jet Stream inlet assembly 27

2 Maintenance 29

Electrospray Ion Source 30

To flush the nebulizer 30

To clean the electrospray spray chamber daily 31

To clean the dual electrospray spray chamber weekly 33

To remove the electrospray nebulizer 37

To replace the electrospray nebulizer needle in the analytical or the reference nebulizer sprayer 38

To adjust the electrospray nebulizer needle 41

Contents

To reinstall the electrospray nebulizer	43
To remove the desolvation assembly	44
To clean skimmer 1	46
To reinstall the desolvation assembly	47
ESI with Agilent Jet Stream Technology	48
To flush the nebulizer daily	48
To flush the nebulizer monthly	49
To clean the spray chamber daily for the ESI with Agilent Jet Stream	50
To clean the spray chamber weekly for the ESI with Agilent Jet Stream	52
To remove the nebulizer for the ESI with Agilent Jet Stream	56
To replace the nebulizer needle for the ESI with Agilent Jet Stream	57
To adjust the nebulizer needle for the ESI with Agilent Jet Stream	60
To reinstall the nebulizer for the ESI with Agilent Jet Stream	62
APCI Source	63
To clean the APCI spray chamber daily	63
To clean the APCI spray chamber weekly	66
To remove the APCI nebulizer	68
To replace the APCI nebulizer needle	69
To adjust the APCI nebulizer needle	72
To reinstall the APCI nebulizer	74
To clean the corona needle	75
To replace the corona needle	77
Multimode Source and HPLC-Chip/MS Interface	79
To clean the multimode source daily	79
To clean the multimode source weekly	81
To adjust the multimode nebulizer	83
To change HPLC-Chip capillaries	86
Ion Transfer Capillary	90
To remove the capillary	90
To clean the capillary	92
To reinstall the capillary	95

Calibrant Delivery System and Divert Valve	96
To check calibrant levels	99
To fill a tuning mix or reference mix bottle	100
To check for leaks	101
To replace the LC filter elements	102
To replace the MS selection valve rotor seal	103
Manifold	105
To open the manifold	105
To close the manifold	106
To disassemble and clean the complete ion optics assembly	107
To remove and clean the complete beam shaping assembly	120
To clean the beam-shaping slicer parts	131
Vacuum System	135
To check the rough pump fluid level	135
To check the oil mist filter	137
To add rough pump fluid	138
To replace the rough pump fluid	140
To replace the fuses	142
3 Reference	145
Safety	146
Environmental Conditions	147
Replaceable Fuses	147

Contents

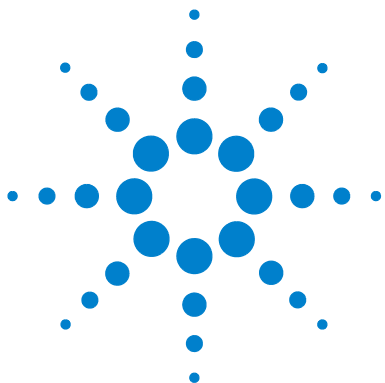

1 Basic Operation

Starting and Shutting Down 10
Changing Ion Sources 19

This chapter describes procedures for the basic operation of your TOF LC/MS instrument.



Figure 1 6224 TOF LC/MS covers. The main power switch is located on the front lower left.

1 Basic Operation



Figure 2 6230 with Agilent Jet Stream Technology

For more details, see the site preparation guide that is sent to customers before installation. If you move the instrument, you must follow and repeat the steps detailed in the site preparation guide.

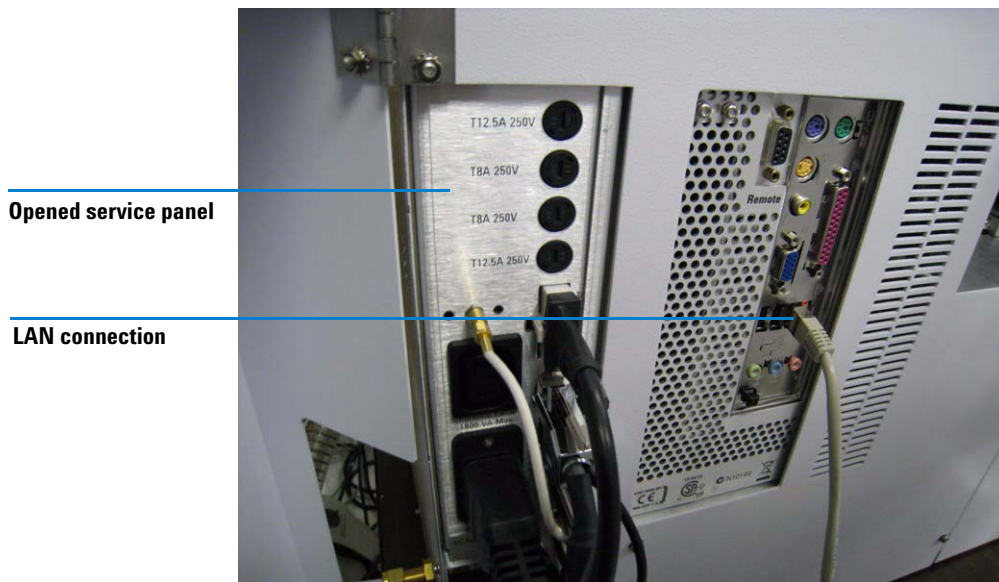

Figure 3 Connections behind service panel

Starting and Shutting Down

This section describes how to start up your TOF LC/MS and how to shut it down.

The TOF LC/MS instruments have three standard modes of operation that you can select from the software.

On Mode *On* is the fully operational status of the system. The instrument and the source are on. The MS TOF icon indicator is green, unless a method is running. When a method is running, the MS TOF icon indicator is blue.

To put an individual device in the On mode, right click the image of the device in the instrument pane and select **On**. To put all devices in the On mode, click the **On** button in the instrument status pane.

Standby Mode In *Standby*, the source interface is on, the drying gas remains heated, and nebulizer flows are maintained. The source and ion optics voltages are turned off, and the mass spectrometer is not sending spectra to the PC. However, the TOF high voltage electronics are on.

For APCI and MMI sources, the vaporizer gas heaters are turned down.

For the 6230 with Agilent Jet Stream inlet assembly, the sheath gas temperature, drying gas flow, and drying gas temperatures are reduced.

This mode lets the instrument remain idle for periods lasting from minutes to days. You should place the instrument in Standby mode when it is not in use or when you want to change the ion source.

To put an individual device in the Standby mode, right click the image of the device in the instrument pane and select **Standby**. To put all devices in the Standby mode, click the **Standby** button in the instrument panel.

Off Mode In *Off* mode, the source interface temperatures and voltages are turned off. The flight assembly high voltages are also turned off.

If a serious error occurs, such as the loss of drying gas or nebulizer gas, the instrument is set automatically to the Off mode. Simultaneously, the status indicator displays “Error” and the MS TOF icon turns red.

However, the vacuum system is still on and the software is running. When you put the system back to the On mode from the Off mode after an extended period of time, allow several hours for the flight assembly voltages to achieve optimal stability.

To put an individual device in the Off mode, right click the image of the device in the instrument pane and select **Off**.

**Powered Off
State**

When the system is in the powered off state, the system is vented and the instrument is turned off to allow maintenance or to prepare for long periods when the instrument is not used.

NOTE

Before you move the instrument to another location, maintain it, or expect it to be idle for long periods of time, turn off both the front switch and the main power breaker switch behind the service panel.

1 Basic Operation

To start the system in Standby mode

To start the system in Standby mode

This procedure brings the system from the powered off state to Standby mode.

- 1 Check that nitrogen gas for the drying gas and for the collision cell are turned on.

When you use the 6230 with Agilent Jet Stream Technology, the drying gas requirements are greater than when operating with ESI, APCI, APPI, or multimode sources. The supply line must have two hydrocarbon traps (part number BHT-4) plumbed in parallel to achieve these flows without triggering errors at the instrument. Refer to the *Installation Guide* for more details.

- 2 Check that the rough pump is connected to the TOF LC/MS.
 - Check that the rough pump power cable is connected to the **Foreline Pump** power receptacle behind the service panel of the TOF LC/MS.
 - Check that the rough pump has the correct voltage rating for your AC power (230 V or 208 V).
 - Check that the rough vacuum tubing is connected to the inlet part of the rough pump.
 - Check that the switch on the rough pump is in the On position.

NOTE

A silicone rubber septum is placed between the spray shield and the capillary for shipment. Make sure that this rubber septum is removed if you are starting the system for the first time.

CAUTION

Do not connect the spray chamber exhaust bottle to the rough pump exhaust tubing or the rough pump exhaust tubing to the spray chamber exhaust tubing. Doing so can contaminate the instrument with rough pump fluid.

- 3 Check that all pump and spray chamber exhausts are vented outside the laboratory.

CAUTION

Vent all exhausts external to the building where they cannot be recirculated by environmental control systems. Do not vent exhaust into your laboratory. The exhaust fumes from the vacuum pumps and spray chamber contains trace amounts of the chemicals you analyze. Health hazards include chemical toxicity from solvents, buffers, samples and pump fluid vapor, as well as potentially biohazardous aerosols of biological samples.

The oil mist filter must be installed on the rough pump, and the ballast valve must be closed. Open the ballast valve periodically (must be done on a weekly basis) to return any oil that has condensed in the oil mist filter to the pump as needed.

- 4 Turn on the power for the computer and monitor.
- 5 Check that the instrument is plugged into a power outlet.
- 6 Turn on the front switch of the TOF LC/MS.

This starts the pumping system and the electronics.

- 7 After Windows starts, click **Start > Programs > Agilent > MassHunter Workstation > Acq Tools > TOF Diagnostics** to start the TOF diagnostics program.
- 8 From the Connection pull-down menu, select **Connect** and click **OK**.
- 9 In the System Turnon section mark the check boxes for **Pump Down** and **HV Condition**.
- 10 Click the **Start** button in the System Turnon window.

The system monitors the vacuum pressure. Once the vacuum pressure reaches 3×10^{-6} torr, the system will begin conditioning the high voltage electronics.

- 11 Once high voltage conditioning has completed, go to **Start > Programs > Agilent > MassHunter Workstation > Data Acquisition** to start the MassHunter Acquisition program.

The system will come up in Standby mode.

By default, the Dual ESI source values are set to:

- Drying gas flow: 3.5 L/minute.
- Drying gas temperature: 300 °C
- Nebulizing gas pressure: 20 psi.

1 Basic Operation

To start the system in Standby mode

NOTE

You will not be able to set the flows while the TOF system is in a “Not Ready” state. The system will remain in the Not Ready state while the high vacuum pressure is above 3.5×10^{-6} torr.

12 Allow the instrument to continue pumping down.

The Rough Vac (rough pump) pressure should be about 1.75 to 2.5 torr. The TOF Vac (flight tube region) pressure should be approximately 3×10^{-6} torr within two to three hours. The TOF Vac reading should be in the 10^{-7} torr range after pumping overnight to several days.

Leave the instrument in Standby.

To change from Standby to On

Use this procedure when the TOF LC/MS is in Standby mode and you need to bring it into the On mode.

Before you begin, check that:

- The TOF LC/MS is in Standby mode

1 In the MassHunter Acquisition program, click **On**.

You can only activate the Standby mode or On mode if the ion source is mounted and closed. You can now select parameters for your measurement.

2 Turn on the LC and the TOF LC/MS instrument.

Click **On** in **Status** pane to turn on the instrument.

The instrument is now in the On mode.

1 Basic Operation

To change from On to Standby

To change from On to Standby

Put the TOF LC/MS in Standby mode when you have completed your analysis of samples.

Before you begin, check that:

- You have completed tuning and data acquisition and you have saved all data as needed (described in later chapters).
- In the MassHunter Acquisition program, click **Standby**.

The drying gas flow, drying gas temperature, nebulizer pressure, vaporizer temperature, and sheath gas temperature are reduced when the instrument is in Standby mode. The spray chamber high voltages are turned off in Standby mode. Voltages in the flight tube remain On in Standby mode to maintain stable operating voltages. The mass spectrometer stops generating spectra.

The system is now in Standby mode.

To shut down the instrument

You can turn off the TOF LC/MS when the instrument will be idle for an extended time or when you must do maintenance.

Before you begin, check that you have completed tuning and data acquisition and you have saved all data as needed.

CAUTION

When you choose Vent from the MS TOF shortcut menu, the TOF LC/MS does not turn off. You must follow the entire shutdown procedure.

WARNING

The spray shield and related spray chamber components are likely to be hot. Do not touch them!

- 1 Turn off the solvent flow.

If you have analyte in any of the components in the sample delivery system, flush the delivery system with pure solvent before you continue.

- 2 Check that the ballast valve on the rough pump is closed.
- 3 In the MassHunter Acquisition program, right-click on the TOF icon and select **Vent**.

When you vent the system, these parts are turned off: spray chamber high voltages, the drying gas heater, the nebulization flow, the detector, and other lens voltages. The drying gas flow is set to 3.5 L/minute. If the APCI source is installed, the vaporizer heater is also turned off. If you have a 6230 with Agilent Jet Stream Technology, the sheath gas heater is also turned off.

The Rough Pump turns off when the turbo speed is below 20 percent.

- 4 Wait until the instrument completely vents (reaching 760 torr) to ensure that the flight tube is filled with nitrogen.

This protects the detector from moisture damage.

- 5 Turn off the front switch located in the lower left front corner of the instrument.
- 6 Turn off the main breaker located behind the service panel.

1 Basic Operation

To shut down the instrument

- 7** At this point, you can also shut down the PC. The system is now shut down.

Changing Ion Sources

This section describes the steps to change from one ion source to another. First, you need to follow the set of steps to remove your current source. Then, you need to follow the steps to install the new source.

To remove an electrospray source

WARNING

The spray chamber operates at very high temperatures. Let the spray chamber cool before you continue.

- 1 Put the instrument in Standby mode.
- 2 Slide open the nebulizer cover.
- 3 Disconnect the LC nebulizer tubing and LC nebulizing gas tubing.
- 4 Disconnect the Reference nebulizer tubing and Reference nebulizing gas tubing.
- 5 Open the spray chamber.
- 6 Plug the reference nebulizer gas outlet on the side of the instrument, under the service panel.
- 7 Remove the spray chamber by lifting it along the axis of its hinges.

To remove the ESI with Agilent Jet Stream Technology

WARNING

The spray chamber operates at very high temperatures. Let the spray chamber cool before you continue.

- 1 Put the instrument in standby mode.

If the ESI with Agilent Jet Stream Technology is at operating temperature (for example 400°C, it may take 20 to 30 minutes to cool down to an acceptable temperature.

- 2 Disconnect the LC tubing and LC nebulizing gas tubing.
- 3 Disconnect the heater and high voltage cables.
- 4 Disconnect the sheath gas line at the connector and unplug it.
- 5 Open the spray chamber.
- 6 Remove the spray chamber by lifting it along the axis of its hinges.
- 7 Remove the Agilent jet stream spray cap.
- 8 If you are changing to a different source type, replace the spray shield with one that is appropriate for the new source type.

To remove a multimode source

- 1 Put instrument in Standby mode.
- 2 Disconnect the electrical connectors to the multimode source.

WARNING

The spray chamber operates at very high temperatures. Let the spray chamber cool for 10 minutes before you continue.

- 3 Disconnect the nebulizing gas tubing and LC tubing from the nebulizer.
- 4 Open the spray chamber.
- 5 Remove the spray chamber by lifting it along the axis of its hinges.
- 6 If you are changing to a different source type, replace the spray shield with one that is appropriate for the new source type.

To remove an APCI or APPI source

- 1 Put instrument in Standby mode.
- 2 Disconnect the APCI or APPI heater cable.
- 3 For APCI source only, disconnect the APCI high voltage cable.

WARNING

The spray chamber operates at very high temperatures. Let the spray chamber cool for 10 minutes before you continue.

- 4 Disconnect the nebulizing gas tubing and LC tubing from the nebulizer.
- 5 Open the spray chamber.
- 6 Remove the spray chamber by lifting it along the axis of its hinges.
- 7 If you are changing to a different source type, replace the spray shield with one that is appropriate for the new source type.

1 Basic Operation

To remove a nano ESI source

To remove a nano ESI source

WARNING

The spray chamber operates at very high temperatures. Let the spray chamber cool before you continue.

- 1 Put instrument in Standby mode.
- 2 Remove the nanospray needle assembly from the source.
- 3 Clean the nanospray needle with 100% acetonitrile. You can also use any solvent that dissolves the last sample run.

CAUTION

Do not let the sample recrystallize inside the needle, which leads to plugged needles. Follow the steps above to prevent plugged needles.

- 4 Disconnect the power cable from the lamp.
- 5 Open the spray chamber.
- 6 Remove the spray chamber by lifting it along the axis of its hinges.
- 7 Remove the capillary cap and drying gas diverter.
- 8 Install the standard capillary cap.
- 9 If you are changing to a different source type, replace the spray shield with one that is appropriate for the new source type.

To remove a dual nano ESI source

WARNING

Do not touch the top of the dual nanospray source or the capillary cap. They may be very hot. Let the parts cool before you handle them.

- 1 Put instrument in Standby mode.
- 2 Remove the reference and LC nanospray needle assembly from the source.
- 3 Clean both nanospray needles with 100% acetonitrile. You can also use any solvent that dissolves the last sample run.

CAUTION

Do not let the sample recrystallize inside the needle, which leads to plugged needles. Follow the steps above to prevent plugged needles.

- 4 Disconnect the power cable from the lamp.
- 5 Open the spray chamber.
- 6 Remove the spray chamber by lifting it along the axis of its hinges.
- 7 Remove the capillary cap and drying gas diverter.
- 8 Install the standard capillary cap and spray shield. For the standard spray shield, the small drying gas exit hole should be oriented above the main hole, or entrance to the capillary cap.

To install an electrospray source

- 1 Install the ESI spray shield.

Make sure the small hole is at the top (“12 o'clock position”). If needed, use a T10 Torx drive to loosen the two screws in the end plate, and rotate the ESI spray shield clockwise until the hole is in the correct position. Gently tighten the Torx screws again.

- 2 Install the electrospray spray chamber.
- 3 Close the spray chamber.
- 4 Connect the nebulizing gas tubing and LC tubing to the analytical nebulizer.
- 5 Connect the nebulizing gas tubing and LC tubing to the reference nebulizer.

CAUTION

Do not touch the nebulizer tip to any surface. The needle is not protected. If you damage the needle, you get bad system performance.

- 6 In the left side of the **MS TOF** tab, in the Method pane, select **Dual ESI** as the **Ion Source**.

- 7 Click **Apply**.

The title bar of the TOF instrument module in the status pane changes from a red to gray color.

- 8 Click the TOF instrument in the Status Panel, then click **On** to turn on the instrument.
- 9 While you wait for the source to reach its working temperature, continue to create the acquisition method, or load a previously stored method.

If you load a method that was stored when using a different ion source, the TOF instrument status turns red. Repeat [step 6](#) and [step 7](#) to enable the current source, and then save the method.

When the source reaches its working temperature, you can use the instrument for analysis.

To install an APCI source

- 1 Install the ESI spray shield.

Make sure the small hole is at the top (“12 o'clock position”). If needed, use a T10 Torx drive to loosen the two screws in the end plate, and rotate the ESI spray shield clockwise until the hole is in the correct position. Gently tighten the Torx screws again.

- 2 Close the ESI reference nebulizer gas tubing with a cap. A threaded plug is provided for this purpose.
- 3 Install the APCI spray chamber.
- 4 Close the spray chamber.
- 5 Connect the nebulizing gas tubing and LC tubing to the APCI nebulizer.
- 6 Connect the APCI heater cable and the APCI high voltage cable.
- 7 In the left side of the **MS TOF** tab, in the Method pane, select **APCI** as the **Ion Source**.
- 8 Click **Apply**.
- 9 Put the instrument in **On** mode.

Let the source heat to its working temperature. Typically, this takes about 15 minutes.

- 10 Load or create the desired analytical method.

This will load the appropriate gas flows and temperature setpoints.

- 11 Rinse a clean bottle with acetonitrile.

The ship kit comes with an extra bottle (p/n 9300-2576) and bottle cap (p/n 9300-2575).

- 12 Pour the APCI/APPI Tuning Mix into the tuning mix bottle.
- 13 Attach the tuning mix bottle back onto the CDS.

1 Basic Operation

To install an APPI source

To install an APPI source

- 1 Install the ESI spray shield.
- 2 Install the APPI USB to Serial Converter Cable (p/n 8121-1013) to the one of the available USB ports on the SmartCard 4 Plus on the left side of the TOF instrument.
- 3 Rinse a clean bottle with acetonitrile.

The ship kit comes with an extra bottle (p/n 9300-2576) and bottle cap (p/n 9300-2575).
- 4 Pour the APCI/APPI Tuning Mix into the tuning mix bottle.
- 5 Attach the tuning mix bottle back onto the CDS.
- 6 Remove the currently installed source and install the G1971B APPI source onto the spray chamber mounts.
- 7 Connect the APPI Vaporizer heater cable to its connector on the left side of the TOF. Then connect the APPI serial cable to the USB/Serial Converter cable that was installed in step 1 of this procedure.

To install a nano ESI, dual nano ESI or multimode source or HPLC-Chip/MS interface

- Refer to the *User Guide* for the specific source or interface.

To install the Agilent Jet Stream inlet assembly

- 1 Install the Agilent Jet Stream spray shield.
- 2 Attach the Agilent Jet Stream inlet assembly to the desolvation chamber.
- 3 Close the latch on the Agilent Jet Stream inlet assembly.
- 4 Remove the plug from the reference nebulizer gas line and connect the sheath gas tubing to the gas line.
- 5 Connect the electrical connections.
- 6 Connect the nebulizer gas line and LC tubing to the nebulizer.
- 7 On the **MS-TOF** tab, on the left side of the **Method** pane, select **ESI**.
- 8 Click **Apply**. The sheath gas will turn on.
- 9 Click **On** to turn on the instrument. The Agilent Jet Stream inlet assembly will begin to heat to the setpoints.
- 10 Load an appropriate method or create one, and allow the system to stabilize.
- 11 If needed, install the ESI-L tuning mix in the reference B port of the CDS.

1 Basic Operation

To install the Agilent Jet Stream inlet assembly

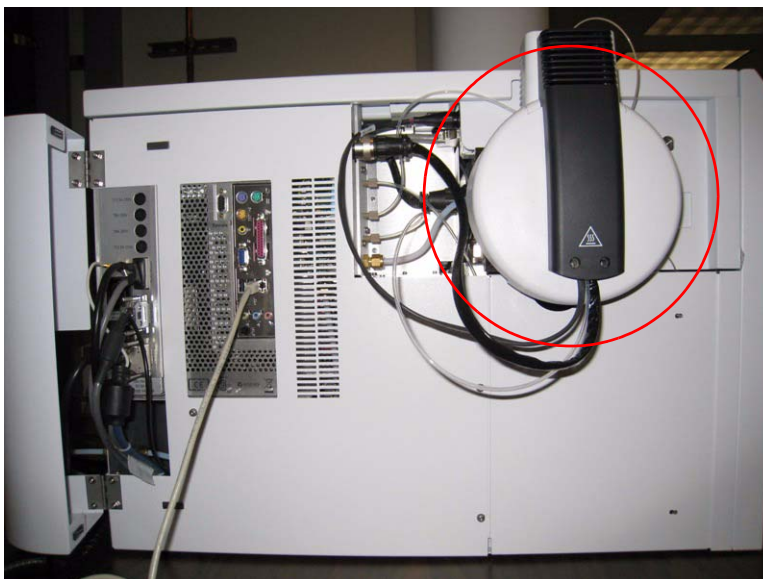
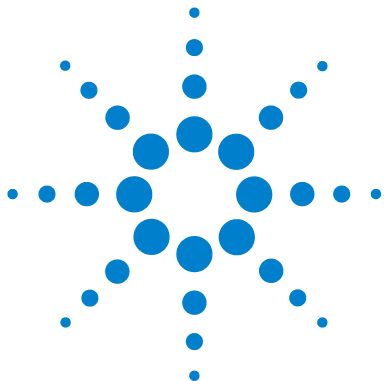

Figure 4 6230 with Agilent Jet Stream inlet assembly (circled) attached. Note the open service panel on the left.



2 Maintenance

Electrospray Ion Source	30
ESI with Agilent Jet Stream Technology	48
APCI Source	63
Multimode Source and HPLC-Chip/MS Interface	79
Ion Transfer Capillary	90
Calibrant Delivery System and Divert Valve	96
Manifold	105
Vacuum System	135

This chapter contains maintenance tasks for the 6224/6230 Series TOF LC/MS System.



Electrospray Ion Source

This section describes the removal, disassembly, cleaning, and reassembly of the API-interface and the assemblies that make up the source.

To flush the nebulizer

When required Daily or at the end of each shift (or more often) to flush traces of samples and buffers out of the tubing, valves and nebulizer.

Tools required

- Acetonitrile, HPLC-grade or better
- Water, HPLC-grade or better

Parts required None

1 Make sure acetonitrile and water are two of the solvents installed in your liquid chromatograph.

NOTE

This procedure applies to both electrospray and APCI nebulizer.

2 Set the liquid chromatograph to pump a mixture of 90% acetonitrile and 10% water at 2 ml/minute.

3 Pump this mixture through the nebulizer for 3 minutes.

NOTE

This is a good general-purpose flushing mixture but you may need to adjust it based on the solvents, samples and buffers you are using. For example, a mixture of 50% acetonitrile and 50% water works well for removing salts.

To clean the electrospray spray chamber daily

When required Daily or at the end of each shift or anytime you suspect carryover contamination from one sample or analysis to another.

Tools required

- Cloths, clean, lint-free (p/n 05980-60051)
- Gloves, clean
- Isopropanol, reagent grade or better
- Mobile phase, current
- Wash bottle, clean
- Water, reagent-grade or better

Parts required None

NOTE

Recent residue should be soluble in the mobile phase. If you are not sure what mobile phase was used recently, a mixture of 50% isopropanol and 50% water works well as a general cleaning solution.

- 1 Prepare the mobile phase you have been using.
- 2 Turn off the spray chamber.

WARNING

The electrospray spray chamber operates at high temperatures. Allow sufficient time to cool down before cleaning.

- 3 Remove the electrospray nebulizer.
- 4 Open the spray chamber ([Figure 1](#)).

2 Maintenance

To clean the electrospray spray chamber daily



Figure 1 Opened electrospray spray chamber

- 5 Rinse the interior of the spray chamber with the current mobile phase or with a mixture of isopropanol and water.

WARNING

Some mobile phases are dangerous. Use the degree of caution appropriate for the mobile phase being used.

- 6 Wipe the interior of the spray chamber with a clean, lint-free cloth.
- 7 Rinse the area around the spray shield.

CAUTION

Do not spray directly toward the tip of the capillary. This can cause pressure surges in the vacuum system.

- 8 Dampen a clean cloth with the mobile phase.
- 9 Wipe the spray shield and the area around the spray shield.
- 10 Close the spray chamber.

WARNING

Use the weekly cleaning procedure if symptoms of contamination persist or if the spray shield or capillary cap show significant discoloration that cannot be removed by the regular, daily cleaning.

To clean the dual electrospray spray chamber weekly

When required Weekly or whenever symptoms indicate that contamination exists in the spray chamber and normal daily cleaning does not correct the problem.

- Tools required**
- Abrasive paper, 4000 grit (p/n 8660-0827)
 - Cloths, clean, lint-free (p/n 05980-60051)
 - Cotton swabs (p/n 5080-5400)
 - Gloves, clean
 - Isopropanol, reagent grade or better
 - Mobile phase, current
 - Wash bottle, clean
 - Water, reagent-grade or better

Parts required None

NOTE

Recent residue should be soluble in the mobile phase. If you are not sure what mobile phase was used recently, a mixture of 50% isopropanol and 50% water works well as a general cleaning solution.

1 Turn off the spray chamber.

WARNING

The electrospray spray chamber operates at high temperatures. Allow sufficient time to cool down.

-
- 2 Remove the electrospray nebulizer.
 - 3 Open the spray chamber and remove it from the instrument.
 - 4 Fill the spray chamber with clean mobile phase, or with a mixture of isopropanol and water.

2 Maintenance

To clean the dual electrospray spray chamber weekly



Figure 2 Filling the spray chamber

WARNING

Some mobile phases are dangerous. Use the degree of caution appropriate for the mobile phase being used.

- 5 Scrub the insulators and the interior of the spray chamber with a clean cotton swab.
- 6 Empty the spray chamber.
- 7 Reinstall the spray chamber on the instrument.
- 8 Remove the spray shield.
- 9 Use abrasive paper to gently clean the end of the capillary cap.

To clean the dual electrospray spray chamber weekly

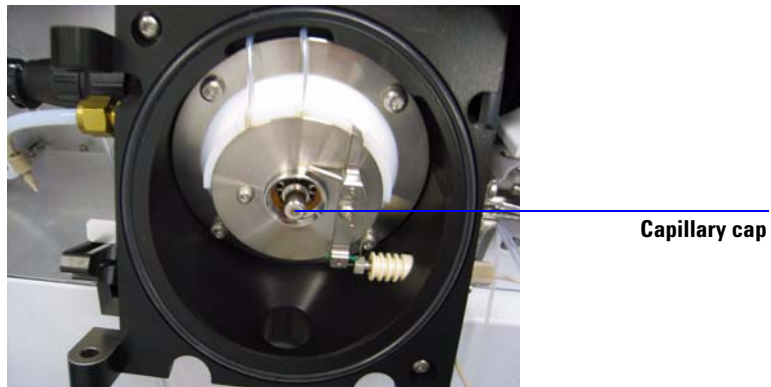

Figure 3 End of capillary cap

10 Dampen a clean cloth and wipe the end of the capillary cap.

11 Reinstall the spray shield.

12 Use abrasive paper to gently clean the spray shield.

13 Dampen a clean cloth and wipe the spray shield.

14 Rinse the area around the spray shield.

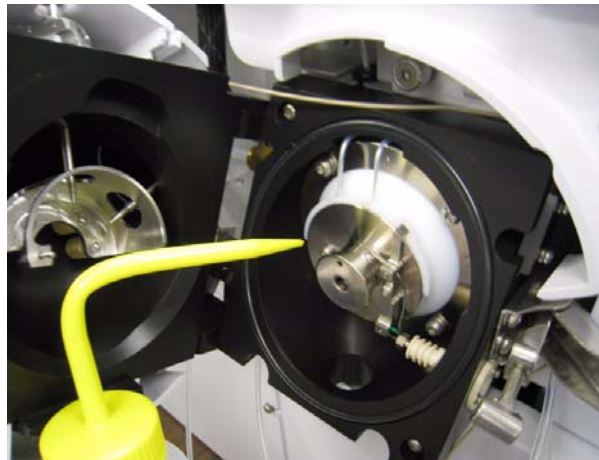

Figure 4 Rinsing the area around the spray shield

2 Maintenance

To clean the dual electrospray spray chamber weekly

CAUTION

Do not spray directly toward the tip of the capillary. This can cause pressure surges in the vacuum system.

15 Wipe the area around the spray shield.

16 Close the spray chamber.

17 Reinstall the electrospray nebulizer and the reference nebulizer.

To remove the electrospray nebulizer

When required When you need to access the nebulizer for maintenance.

Tools required Gloves, clean

Parts required None

NOTE

Recent residue should be soluble in the mobile phase. If you are not sure what mobile phase was used recently, a mixture of 50% isopropanol and 50% water works well as a general cleaning solution.



Figure 5 Electrospray nebulizer

- 1 Shut off the flow of LC solvent.
- 2 Shut off the flow of nebulizing gas.
- 3 Slide back the plastic cover from over the nebulizer.
- 4 Disconnect the LC tubing and nebulizing gas tubing from the nebulizer.
- 5 Turn the nebulizer counterclockwise until it disengages from the retaining screws.
- 6 Gently lift the nebulizer out of the spray chamber.

WARNING

The tip of the nebulizer may be very hot. Allow it to cool before handling it.

2 Maintenance

To replace the electrospray nebulizer needle in the analytical or the reference nebulizer sprayer

To replace the electrospray nebulizer needle in the analytical or the reference nebulizer sprayer

When required When the needle is plugged. Common symptoms of a plugged needle are increased LC back pressure or off-axis spraying or dripping from the nebulizer or when the reference nebulizer needle is not spraying.

Tools required

- Adjustment fixture (p/n G1946-20215)
- Gloves, clean
- Pliers, long nose (p/n 7810-0004)
- Wrench 3-mm, open-end (p/n 8710-2699)
- Wrench ¼-inch x 5/16-inch, open-end (p/n 8710-0510)

Parts required Electrospray nebulizer needle kit (includes needle, ferrule, and needle holder, p/n G2427A)



Figure 6 Electrospray nebulizer needle in needle holder

- 1 Install the nebulizer in the adjustment fixture.
- 2 Loosen the locknut next to the zero-dead-volume (ZDV) union.
- 3 Remove the union from the nebulizer.
- 4 Loosen the locknut of the needle holder.
- 5 Unscrew the needle holder and pull it out of the nebulizer.
- 6 Slide the non-tapered end of the needle through the new needle holder from the narrower side.

To replace the electrospray nebulizer needle in the analytical or the reference nebulizer sprayer

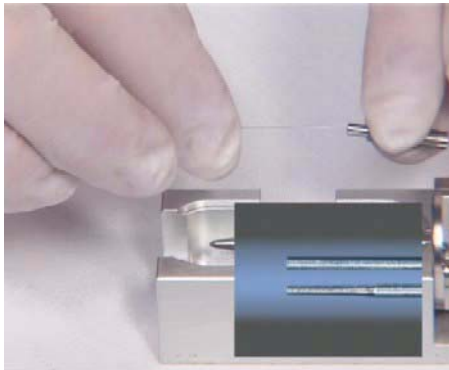

Figure 7 Sliding the non-tapered end of the needle through the new needle holder

- 7 Push a new ferrule, flat-side first, onto the needle.
- 8 Be sure the needle does not extend from the ferrule.
- 9 Reinstall the locknut and the union. Hand tighten the union.
- 10 Hold the needle holder steady with a 3-mm wrench. Tighten the union one-quarter to one-half turn to compress the ferrule.

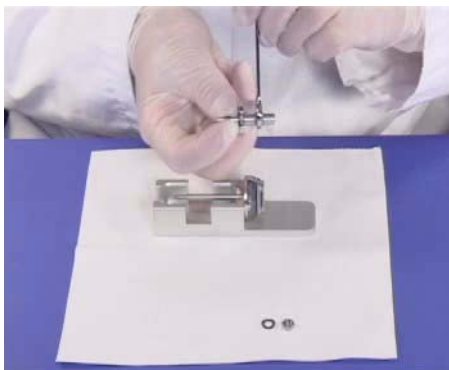

Figure 8 Tightening the union screw to compress the ferrule

- 11 Tighten the locknut against the union.
- 12 Pull carefully on the needle to ensure the needle is held firmly in place.
- 13 Replace locknut and washer.
- 14 Insert the needle into the nebulizer shaft.

2 Maintenance

To replace the electrospray nebulizer needle in the analytical or the reference nebulizer sprayer

CAUTION

Take care when inserting the needle. The tapered end of the needle must pass through the restrictions in the nebulizer shaft. The tip of the needle can be damaged if excessive force is applied.

15 Adjust the electrospray needle position before reinstalling the nebulizer in the spray chamber.

NOTE

Record this procedure in the Maintenance Logbook.

To adjust the electrospray nebulizer needle

When required After replacing the electrospray nebulizer needle or if symptoms indicate the needle is not correctly adjusted,

- Tools required**
- Adjustment fixture (p/n G1946-20215)
 - Gloves, clean
 - Magnifier (p/n G1946-80049)
 - Wrench 3-mm, open-end (p/n 8710-2699)
 - Wrench $\frac{1}{4}$ -inch x $\frac{5}{16}$ -inch, open-end (p/n 8710-0510)

Parts required None

- 1 Install the nebulizer in the adjustment fixture.

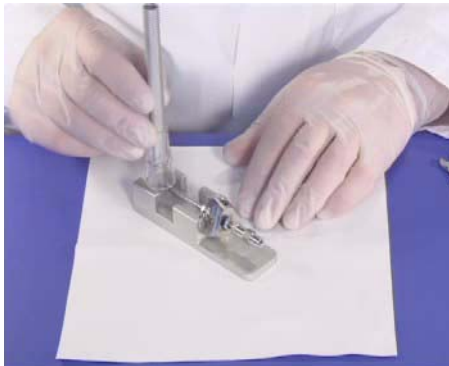

Figure 9

- 2 Loosen the needle holder locknut.
- 3 Position the magnifier so you can see the tip of the nebulizer.
- 4 Adjust the needle holder until the needle is even with the tip of the nebulizer.

2 Maintenance

To adjust the electrospray nebulizer needle

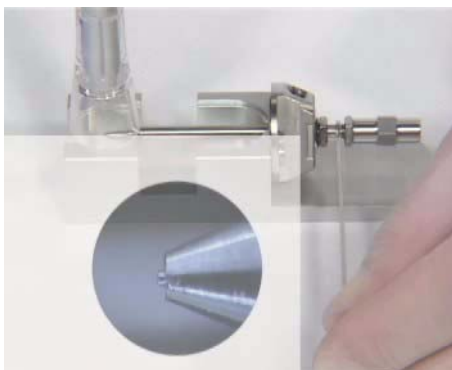

Figure 10 Adjusting the needle holder

- 5** Tighten the locknut. Make sure this does not change the position of the needle.
- 6** Remove the nebulizer from the adjustment fixture and reinstall it in the electrospray spray chamber.
- 7** Be very careful not to hit the tip of the nebulizer against anything. Any damage will have a large, negative effect on system performance.

NOTE

Record this procedure in the Maintenance Logbook.

To reinstall the electrospray nebulizer

When required As necessary.

Tools required None

Parts required None

1 Insert the nebulizer part way into the spray chamber.

CAUTION

Do not hit the tip of the needle as you insert the nebulizer. The tip of the needle is easily damaged.

2 Reconnect the nebulizing gas tubing to the nebulizer.

3 Finish inserting the nebulizer into the spray chamber.

4 Turn the nebulizer clockwise and lock it in place.

5 Reconnect the LC tubing to the nebulizer.

CAUTION

Do not overtighten the LC fitting. Overtightening the fitting can crush the tubing, creating a restriction.

6 Close the nebulizer cover.

2 Maintenance

To remove the desolvation assembly

To remove the desolvation assembly

When required When you need to access the optics assembly.

Tools required

- Wrench, ½-inch x 9/16-inch, open-end (p/n 8710-0877)
- Screwdriver, TORX, T-20 (p/n 8710-1615)

Parts required None

WARNING

The spray chamber and desolvation assembly operate at very high temperatures. Give them time to cool before proceeding.

- 1 Vent the system.
- 2 Unplug the instrument power cord from the power outlet after venting is complete.
- 3 Remove the front, top and left side covers.
- 4 Disconnect the connections to the Aux module on top of the vacuum manifold, and lift off and remove the Aux module. Disconnect the drying gas tubing from the desolvation assembly.
- 5 Disconnect the drying gas heater cable from the desolvation assembly.
- 6 Disconnect the drain hose from the desolvation assembly.
- 7 Disconnect the PEEK nut on the tubing from the calibrant delivery system to the desolvation assembly.
- 8 Remove the two retaining screws that keep the desolvation assembly attached to the support rods.

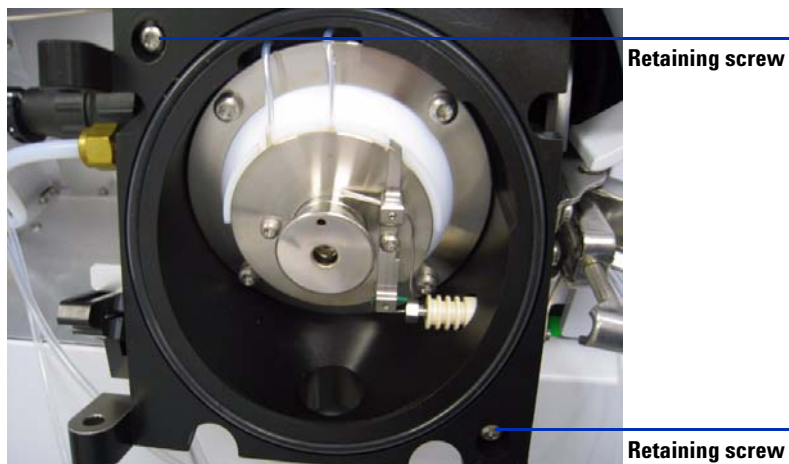

Figure 11 Remove the retaining screws. (6224 with IRM)

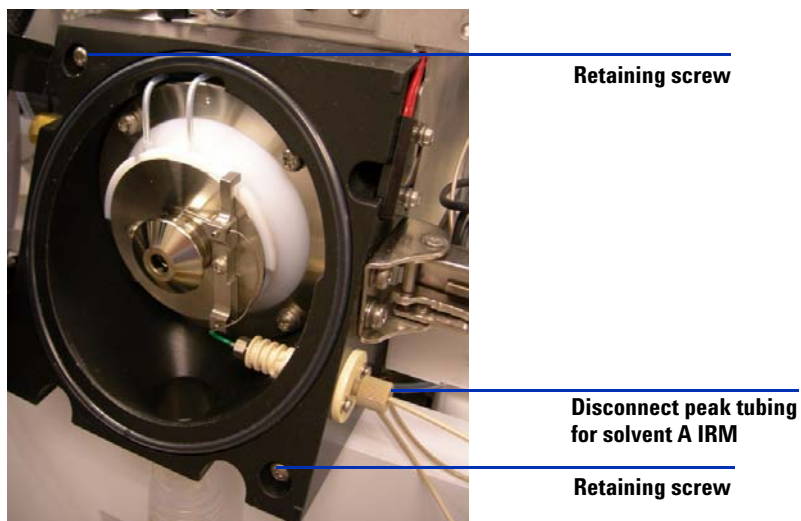

Figure 12 Remove the retaining screws. (6230 with IRM)

9 Slide the desolvation assembly off of the support rods.

NOTE

The capillary column is contained in the desolvation assembly. It does not need to be removed in order to remove the desolvation assembly.

2 Maintenance

To clean skimmer 1

To clean skimmer 1

When required When symptoms indicate it is necessary.

Tools required Cloth, clean, lint-free (p/n 05980-60051)
Gloves, clean
Isopropanol, reagent grade or better
Water, reagent-grade or better

Parts required None

- 1 Remove the desolvation assembly.
- 2 Dampen a clean cloth with a mixture of Isopropanol and water.
- 3 Wipe the skimmer.

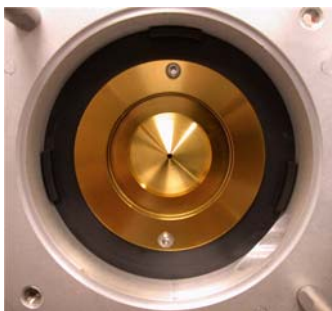

Figure 13 Wipe the skimmer.

CAUTION

The tip of the skimmer is delicate. Do not damage it.

-
- 4 Reinstall the desolvation assembly.

To reinstall the desolvation assembly

When required As necessary.

Tools required Wrench, ½-inch x 9/16-inch, open-end (p/n 8710-0877)

Parts required None

- 1 Put the desolvation assembly on the support rods and slide it back until it seals against the vacuum manifold.
- 2 Install the two retaining screws.
- 3 Reconnect the drain hose to the desolvation assembly.
- 4 Reconnect the drying gas heater cable to the desolvation assembly.
- 5 Reconnect the nebulizing gas tubing to the desolvation assembly.
- 6 Reinstall the Aux module on top of the vacuum manifold.
- 7 Reconnect the connections to the Aux module.

ESI with Agilent Jet Stream Technology

This section describes the removal, disassembly, cleaning, and reassembly of the electrospray interface with Agilent Jet Stream Technology.

To flush the nebulizer daily

When required Daily or at the end of each shift (or more often) to flush traces of samples and buffers out of the tubing, valves and nebulizer

Tools required

- Acetonitrile, HPLC-grade or better
- Water, HPLC-grade or better

Parts required None

- 1 Make sure acetonitrile and water are two of the solvents installed in your liquid chromatograph.
- 2 Set the liquid chromatograph to pump a mixture of 90% acetonitrile and 10% water at 2 ml/minute.
- 3 Pump this mixture through the nebulizer for 3 minutes.

NOTE

This is a good general-purpose flushing mixture but you may need to adjust it based on the solvents, samples and buffers you are using. For example, a mixture of 50% acetonitrile and 50% water works well for removing salts.

To flush the nebulizer monthly

When required Monthly or as needed at the end of each shift (or more often) to flush traces of samples and buffers out of the tubing, valves and nebulizer

Tools required

- HPLC Flushing Solvent
- Cyclohexane, HPLC-grade or better
- Acetonitrile, HPLC grade or better
- Alternatively if available: isooctane, HPLC-grade or better

Parts required None

- 1 Make sure HPLC flushing, cyclohexane, and acetonitrile are three of the solvents installed in your liquid chromatograph.
- 2 Pump HPLC flushing solvent for 10 minutes at 5 mL/minute.
- 3 Switch to cyclohexane, and pump for 10 minutes at 5 mL/minute.
- 4 Pump this mixture through the nebulizer for 3 minutes.
- 5 Prepare enough acetonitrile and flush overnight.

NOTE

This is a good general-purpose flushing mixture but you may need to adjust it based on the solvents, samples and buffers you are using. For example, substitute acetonitrile for isooctane for overnight flushing when heavy build-up is noticeable.

2 Maintenance

To clean the spray chamber daily for the ESI with Agilent Jet Stream

To clean the spray chamber daily for the ESI with Agilent Jet Stream

When required Daily or at the end of each shift or anytime you suspect carryover contamination from one sample or analysis to another

Tools required

- Cloths, clean, lint-free (p/n 05980-60051)
- Gloves, clean
- Isopropanol, reagent grade or better
- Mobile phase, current
- Wash bottle, clean
- Water, reagent-grade or better

Parts required None

NOTE

Recent residue should be soluble in the mobile phase. If you are not sure what mobile phase was used recently, use a mixture of 50% isopropanol and 50% water as a general cleaning solution.

- 1 Prepare the mobile phase you have been using.
- 2 Turn off the spray chamber.

WARNING

The electrospray with Agilent Jet Stream Technology spray chamber operates at high temperatures. Allow sufficient time to cool down before cleaning.

- 3 Remove the nebulizer.
- 4 Open the spray chamber ([Figure 2](#)).

To clean the spray chamber daily for the ESI with Agilent Jet Stream



Figure 14 Opened electrospray Agilent Jet Stream Technology spray chamber

- 5 Rinse the interior of the spray chamber with the current mobile phase or with a mixture of isopropanol and water.

WARNING

Some mobile phases are dangerous. Use the degree of caution appropriate for the mobile phase being used.

- 6 Wipe the interior of the spray chamber with a clean, lint-free cloth.
- 7 Rinse the area around the spray shield.

CAUTION

Do not spray directly toward the tip of the capillary. This can cause pressure surges in the vacuum system.

- 8 Dampen a clean cloth with the mobile phase.
- 9 Wipe the spray shield and the area around the spray shield.
- 10 Close the spray chamber.
- 11 Reinstall the electrospray nebulizer.

NOTE

Use the weekly cleaning procedure if symptoms of contamination persist or if the spray shield or capillary cap show significant discoloration that cannot be removed by the regular, daily cleaning.

2 Maintenance

To clean the spray chamber weekly for the ESI with Agilent Jet Stream

To clean the spray chamber weekly for the ESI with Agilent Jet Stream

When required Weekly or whenever symptoms indicate that contamination exists in the spray chamber and normal daily cleaning does not correct the problem

- Tools required**
- Abrasive paper, 8000 grit (p/n 8660-0852)
 - Cloths, clean, lint-free (p/n 05980-60051)
 - Cotton swabs (p/n 5080-5400)
 - Gloves, clean
 - Isopropanol, reagent grade or better
 - Mobile phase, current
 - Wash bottle, clean
 - Water, reagent-grade or better

Parts required None

NOTE

Recent residue should be soluble in the mobile phase. If you are not sure what mobile phase was used recently, a mixture of 50% isopropanol and 50% water works well as a general cleaning solution.

1 Turn off the spray chamber.

WARNING

The electrospray spray chamber operates at high temperatures. Allow sufficient time to cool down.

2 Remove the electrospray nebulizer.

3 Open the spray chamber and remove it from the LC/MS.

4 Fill the spray chamber with clean mobile phase, or with a mixture of isopropanol and water.

To clean the spray chamber weekly for the ESI with Agilent Jet Stream

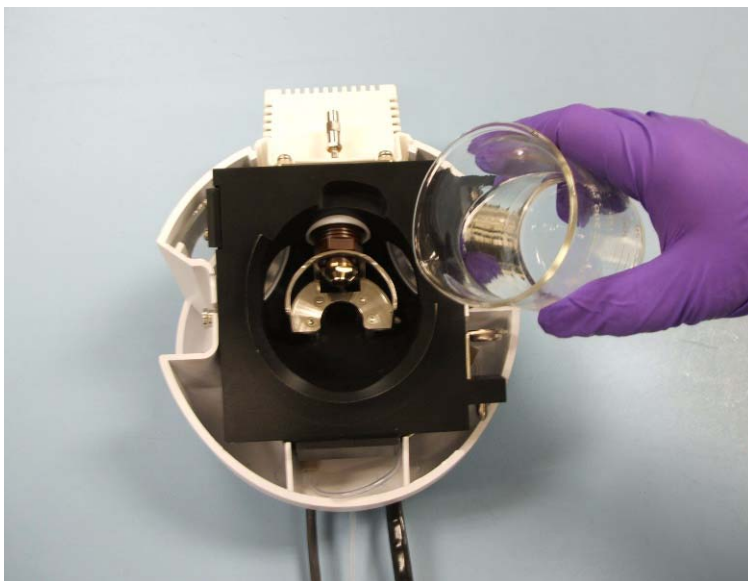

Figure 15 Filling the spray chamber

WARNING

Some mobile phases are dangerous. Use the degree of caution appropriate for the mobile phase being used.

- 5 Scrub the insulators and the interior of the spray chamber with a clean cotton swab.
- 6 Empty the spray chamber.
- 7 Reinstall the spray chamber on the instrument.
- 8 Remove the spray shield.
- 9 Use abrasive paper to gently clean the end of the capillary cap.

2 Maintenance

To clean the spray chamber weekly for the ESI with Agilent Jet Stream

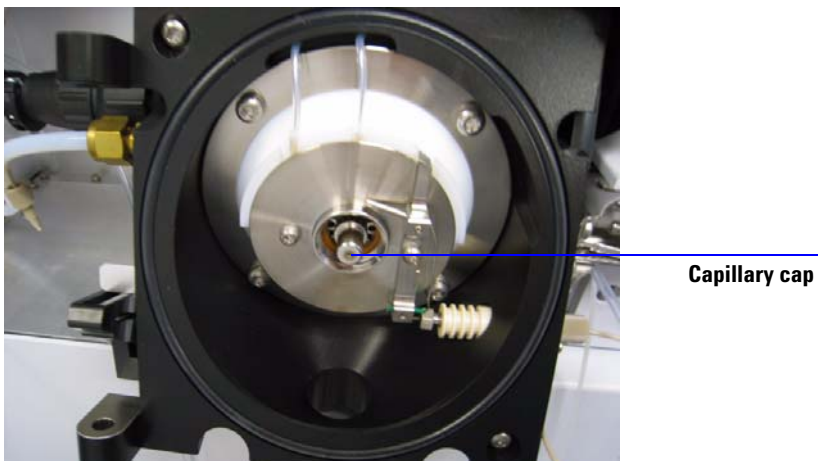

Figure 16 End of capillary cap

10 Dampen a clean cloth and wipe the end of the capillary cap.

11 Reinstall the spray shield.

12 Use abrasive paper to gently clean the spray shield.

13 Dampen a clean cloth and wipe the spray shield.

14 Rinse the area around the spray shield.

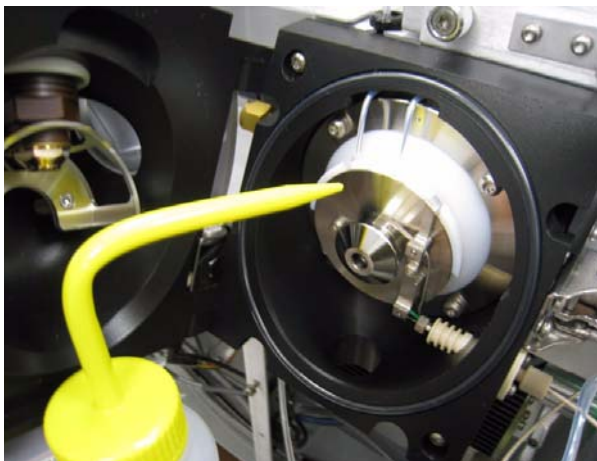

Figure 17 Rinsing the area around the spray shield

To clean the spray chamber weekly for the ESI with Agilent Jet Stream

CAUTION

Do not spray directly toward the tip of the capillary. This can cause pressure surges in the vacuum system.

15 Wipe the area around the spray shield.

16 Close the spray chamber.

17 Reinstall the electrospray nebulizer.

2 Maintenance

To remove the nebulizer for the ESI with Agilent Jet Stream

To remove the nebulizer for the ESI with Agilent Jet Stream

When required When you need to access the nebulizer for maintenance

Tools required Gloves, clean

Parts required None

NOTE

Recent residue should be soluble in the mobile phase. If you are not sure what mobile phase was used recently, a mixture of 50% isopropanol and 50% water works well as a general cleaning solution.



Figure 18 Electrospray nebulizer

- 1 Shut off the flow of LC solvent.
- 2 Shut off the flow of nebulizing gas.
- 3 Slide back the plastic cover from over the nebulizer.
- 4 Disconnect the LC tubing and nebulizing gas tubing from the nebulizer.
- 5 Turn the nebulizer counterclockwise until it disengages from the retaining screws.
- 6 Gently lift the nebulizer out of the spray chamber.

WARNING

The tip of the nebulizer may be very hot. Allow it to cool before handling it.

To replace the nebulizer needle for the ESI with Agilent Jet Stream

When required When the needle is plugged. Common symptoms of a plugged needle are increased LC back pressure or off-axis spraying or dripping from the nebulizer.

- Tools required**
- Adjustment fixture (p/n G1946-20215)
 - Gloves, clean
 - Pliers, long nose (p/n 7810-0004)
 - Wrench 3-mm, open-end (p/n 8710-2699)
 - Wrench ¼-inch x 5/16-inch, open-end (p/n 8710-0510)

Parts required Nebulizer accessory kit, ES with Agilent Jet Stream p/n G1958-60136

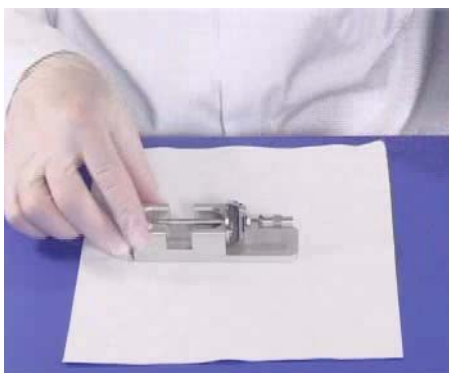

Figure 19 Electro-spray nebulizer needle in needle holder

- 1 Install the nebulizer in the adjustment fixture.
- 2 Loosen the locknut next to the zero-dead-volume (ZDV) union.
- 3 Remove the union from the nebulizer.
- 4 Loosen the locknut of the needle holder.
- 5 Unscrew the needle holder and pull it out of the nebulizer.
- 6 Slide the non-tapered end of the needle through the new needle holder from the narrower side.

2 Maintenance

To replace the nebulizer needle for the ESI with Agilent Jet Stream

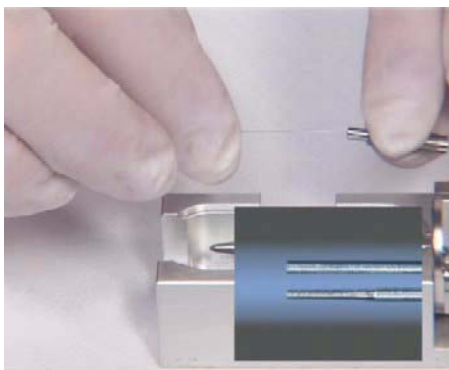

Figure 20 Sliding the non-tapered end of the needle through the new needle holder

- 7 Push a new ferrule, flat-side first, onto the needle.
- 8 Be sure the needle does not extend from the ferrule.
- 9 Reinstall the locknut and the union. Hand tighten the union.
- 10 Hold the needle holder steady with a 3-mm wrench. Tighten the union one-quarter to one-half turn to compress the ferrule.



Figure 21 Tightening the union screw to compress the ferrule

- 11 Tighten the locknut against the union.
- 12 Pull carefully on the needle to ensure the needle is held firmly in place.
- 13 Replace locknut and washer.
- 14 Insert the needle into the nebulizer shaft.

To replace the nebulizer needle for the ESI with Agilent Jet Stream

CAUTION

Take care when inserting the needle. The tapered end of the needle must pass through the restrictions in the nebulizer shaft. The tip of the needle can be damaged if excessive force is applied.

15 Adjust the electrospray needle position before reinstalling the nebulizer in the spray chamber.

NOTE

Record this procedure in the Maintenance Logbook.

2 Maintenance

To adjust the nebulizer needle for the ESI with Agilent Jet Stream

To adjust the nebulizer needle for the ESI with Agilent Jet Stream

When required After replacing the electrospray nebulizer needle or if symptoms indicate the needle is not correctly adjusted

Tools required

- Adjustment fixture (p/n G1946-20215)
- Gloves, clean
- Magnifier (p/n G1946-80049)
- Wrench 3-mm, open-end (p/n 8710-2699)
- Wrench ¼-inch x 5/16-inch, open-end (p/n 8710-0510)

Parts required None

1 Install the nebulizer in the adjustment fixture.



Figure 22

- 2 Loosen the needle holder locknut.
- 3 Position the magnifier so you can see the tip of the nebulizer.
- 4 Adjust the needle holder until the needle is even with the tip of the nebulizer.

To adjust the nebulizer needle for the ESI with Agilent Jet Stream

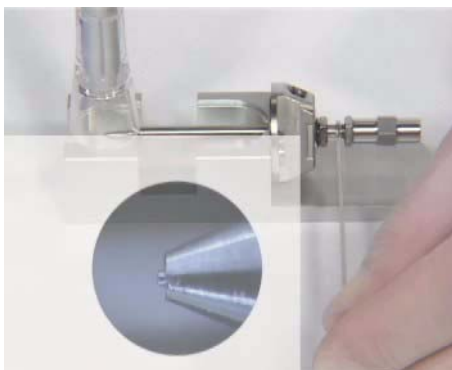

Figure 23 Adjusting the needle holder

- 5** Tighten the locknut. Make sure this does not change the position of the needle.
- 6** Remove the nebulizer from the adjustment fixture and reinstall it in the electrospray spray chamber.
- 7** Be very careful not to hit the tip of the nebulizer against anything. Any damage will have a large, negative effect on system performance.

NOTE

Record this procedure in the Maintenance Logbook.

2 Maintenance

To reinstall the nebulizer for the ESI with Agilent Jet Stream

To reinstall the nebulizer for the ESI with Agilent Jet Stream

When required As necessary

Tools required None

Parts required None

1 Insert the nebulizer part way into the spray chamber.

CAUTION

Do not hit the tip of the needle as you insert the nebulizer. The tip of the needle is easily damaged.

2 Reconnect the nebulizing gas tubing to the nebulizer.

3 Finish inserting the nebulizer into the spray chamber.

4 Turn the nebulizer clockwise and lock it in place.

5 Reconnect the LC tubing the nebulizer.

CAUTION

Do not overtighten the LC fitting. Overtightening the fitting can crush the tubing, which creates restriction.

6 Close the nebulizer cover.

APCI Source

This section describes how to open and close the APCI source and maintain it. To learn how to install and remove the APCI source, see [“To install an APCI source”](#) on page 25 and [“To remove an APCI or APPI source”](#) on page 21.

To clean the APCI spray chamber daily

When required Daily at the end of each shift or anytime you suspect carryover contamination from one sample or analysis to another.

Tools required

- Cloths, clean, lint-free (p/n 05980-60051)
- Gloves, clean
- Isopropanol, reagent grade or better
- Mobile phase, current
- Wash bottle, clean
- Water, reagent-grade or better

Parts required None

WARNING

The APCI spray chamber operates at high temperatures. Allow sufficient time to cool down.

Some mobile phases are dangerous. Use the degree of caution appropriate for the mobile phase being used.

CAUTION

Do not spray the mobile phase upward into the vaporizer.

Do not spray directly toward the tip of the capillary. This can cause pressure surges in the vacuum system.

2 Maintenance

To clean the APCI spray chamber daily

NOTE

- Recent residue should be soluble in the mobile phase. If you are not sure what mobile phase was used recently, use a mixture of 50% isopropanol and 50% water as a general cleaning solution.
- Use the weekly cleaning procedure if symptoms of contamination persist, or if the spray shield or capillary cap shows significant discoloration that cannot be removed by the regular daily cleaning.

- 1 Turn off the spray chamber.
- 2 Remove the corona needle.
- 3 Make sure the needle has cooled and then carefully clean it with abrasive paper.
- 4 Open the spray chamber.



Figure 24 Opened spray chamber

- 5 Rinse the interior of the spray chamber with the current mobile phase or with a mixture of isopropanol and water.
- 6 Wipe the interior of the spray chamber and the end of the vaporizer with a clean cloth.
- 7 Remove the spray shield.
- 8 Use abrasive paper to gently clean the end of the capillary cap.
- 9 Dampen a clean cloth and wipe the end of the capillary cap.
- 10 Reinstall the spray shield.

To clean the APCI spray chamber daily

- 11** Use abrasive paper to gently clean the spray shield.
- 12** Dampen a clean cloth and wipe the spray shield.
- 13** Rinse the area around the spray shield.
- 14** Wipe the area around the spray shield with a clean cloth.
- 15** Close the spray chamber.
- 16** Reinstall the corona needle.

2 Maintenance

To clean the APCI spray chamber weekly

To clean the APCI spray chamber weekly

When required Weekly or whenever symptoms indicate contamination in the spray chamber and the normal daily cleaning does not correct the problem.

- Tools required**
- Abrasive paper, 4000 grit (p/n 8660-0827)
 - Cloth, clean, lint-free, 05980-60051
 - Cotton swabs, 5080-5400
 - Gloves, clean
 - Isopropanol, reagent grade or better
 - Mobile phase, current
 - Wash bottle
 - Water, reagent-grade or better

Parts required None

1 Prepare the mobile phase you have been using.

Recent residue should be soluble in the mobile phase. If you are not sure what mobile phase was used recently, use a mixture of 50% isopropanol and 50% water as a general cleaning solution.

2 Turn off the spray chamber.

3 The APCI spray chamber operates at high temperatures. Allow sufficient time to cool down.

4 Remove the corona needle.

5 Make sure the needle has cooled and then carefully clean it with abrasive paper.

6 Open the spray chamber.

7 Rinse the interior of the spray chamber with the current mobile phase or with a mixture of isopropanol and water.

Some mobile phases are dangerous. Use caution that is appropriate for the current mobile phase.

CAUTION

Do not spray the mobile phase upward into the vaporizer.

To clean the APCI spray chamber weekly

- 8 Wipe the interior of the spray chamber and the end of the vaporizer with a clean cloth.
- 9 Remove the spray shield.
- 10 Use abrasive paper to gently clean the end of the capillary cap.
- 11 Dampen a clean cloth and wipe the end of the capillary cap.
- 12 Reinstall the spray shield.
- 13 Use abrasive paper to gently clean the spray shield.
- 14 Dampen a clean cloth and wipe the spray shield.
- 15 Rinse the area around the spray shield.

CAUTION

Do not spray directly at the end of the capillary. This can cause pressure surges in the vacuum system.

- 16 Wipe the area around the spray shield with a clean cloth.
- 17 Close the spray chamber.
- 18 Reinstall the corona needle.

2 Maintenance

To remove the APCI nebulizer

To remove the APCI nebulizer

When required When you need to access the nebulizer for maintenance.

Tools required • Gloves, clean

Parts required None



Figure 25 APCI nebulizer

- 1 Shut off the flow of LC solvent.
- 2 Shut off the flow of nebulizing gas.
- 3 Disconnect the LC tubing and nebulizing gas tubing from the nebulizer.
- 4 Turn the nebulizer counterclockwise until it disengages from the retaining screws.
- 5 Gently lift the nebulizer out of the spray chamber.

WARNING

The tip of the nebulizer may be very hot. Allow it to cool before handling it.

To replace the APCI nebulizer needle

When required When the needle is plugged. Common symptoms of a plugged needle are increased LC back pressure or off-axis spray from the nebulizer (difficult to see in an APCI system).

Tools required

- Adjustment fixture (p/n G1946-20215)
- Gloves, clean, lint-free (large, p/n 8650-0030; small, p/n 8650-0029)
- Pliers, long-nose (p/n 8710-0004)
- Wrench 3-mm, open-end (p/n G1946-20203)
- Wrench ¼-inch x 5/16-inch, 2 required (p/n 8710-0510)

Parts required Nebulizer needle kit, APCI (includes needle, ferrule, and needle holder, p/n G2428A).

1 Install the nebulizer in the adjustment fixture.

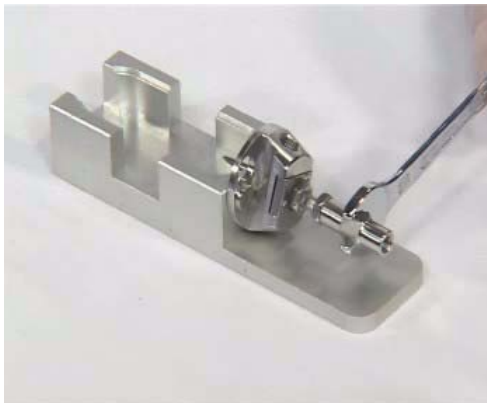

Figure 26 Installing the nebulizer in the adjustment fixture

- 2 Loosen the locknut next to the zero-dead-volume (ZDV) union.
- 3 Remove the union from the nebulizer.
- 4 Loosen the locknut of the needle holder.
- 5 Unscrew the needle holder and pull it out of the nebulizer.
- 6 Slide the non-tapered end of the needle through the new needle holder from the narrower side.

2 Maintenance

To replace the APCI nebulizer needle

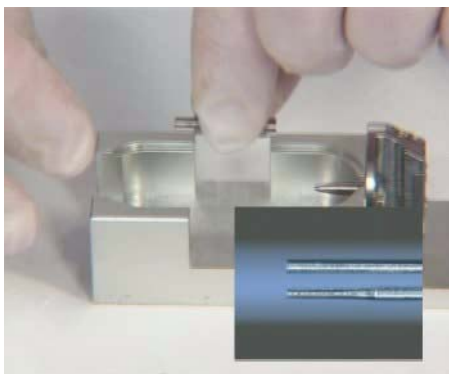

Figure 27 Sliding the non-tapered end of the needle through the new needle holder

- 7 Push a new ferrule, flat-side first, onto the needle.
- 8 Be sure the needle does not extend from the ferrule.
- 9 Reinstall the locknut and the union. Hand tighten the union.
- 10 Hold the needle holder steady with a 3-mm wrench and tighten the union one-quarter to one-half turn to compress the ferrule.

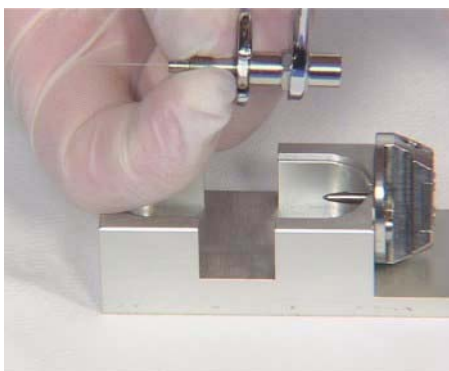

Figure 28 Tightening the union to compress the ferrule

- 11 Tighten the locknut against the union.
- 12 Pull carefully on the needle to ensure the needle is held firmly in place.
- 13 Replace locknut and washer.
- 14 Insert the needle into the nebulizer shaft.

CAUTION

Take care when inserting the needle. The tapered end of the needle must pass through restrictions in the nebulizer shaft. The tip of the needle can be damaged if excessive force is applied.

15 Adjust the APCI needle position before reinstalling the nebulizer in the spray chamber.

NOTE

Record this procedure in the Maintenance Logbook.

2 Maintenance

To adjust the APCI nebulizer needle

To adjust the APCI nebulizer needle

When required After replacing the APCI nebulizer needle or if symptoms indicate the needle may not be correctly adjusted.

Tools required

- Adjustment fixture (p/n G1946-20215)
- Gloves, clean
- Magnifier (p/n G1946-80049)
- Wrench 3-mm, open-end (p/n 8710-2699)
- Wrench $\frac{1}{4}$ -inch x $\frac{5}{16}$ -inch, 2 required (p/n 8710-0510)

Parts required None

1 Install the nebulizer in the adjustment fixture.



Figure 29 Installing the nebulizer in the adjustment fixture

- 2 Loosen the needle holder locknut.
- 3 Position the magnifier so you can view the tip of the nebulizer.
- 4 Adjust the needle holder until the needle is even with the tip of the nebulizer.

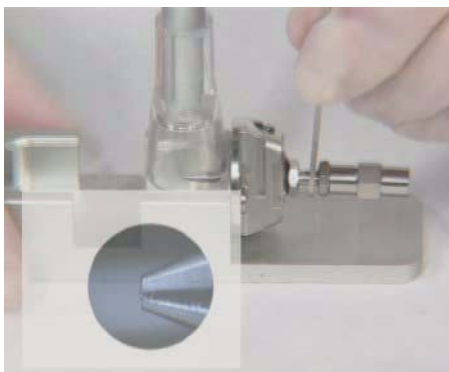

Figure 30 Adjusting the needle holder

- 5** Tighten the locknut. Make sure this does not change the position of the needle.
- 6** Remove the nebulizer from the adjustment fixture and reinstall it in the APCI spray chamber.
- 7** Be very careful not to hit the tip of the nebulizer against anything. Any damage will have a large, negative effect on system performance.

NOTE

Record this procedure in the Maintenance Logbook.

2 Maintenance

To reinstall the APCI nebulizer

To reinstall the APCI nebulizer

When required As necessary.

Tools required None

Parts required None

- 1 Insert the nebulizer into the spray chamber.
- 2 Turn it clockwise to lock it into place.
- 3 Reconnect the nebulizing gas tubing to the nebulizer.
- 4 Reconnect the LC tubing to the zero-dead-volume union.
- 5 Do not overtighten the LC fitting. Overtightening the fitting can crush the tubing, creating a restriction.

To clean the corona needle

When required When you observe decrease sensitivity, decreased signal stability, and increase corona voltage during APCI operation.

- Tools required**
- Abrasive paper, 4000 grit (p/n 8660-0827)
 - Cloths, clean, lint-free (p/n 05980-60051)
 - Gloves, clean
 - Isopropanol, reagent grade or better

Parts required None

- 1 Pull the corona needle assembly out of the spray chamber.

WARNING

The needle and related parts get very hot during operation. Make sure they have cooled before proceeding.



Figure 31 Dirty APCI corona needle.

- 2 Fold a piece of abrasive paper over the base of the needle.
- 3 Pull and twist the abrasive paper along the needle and off the tip of the needle.

2 Maintenance

To clean the corona needle

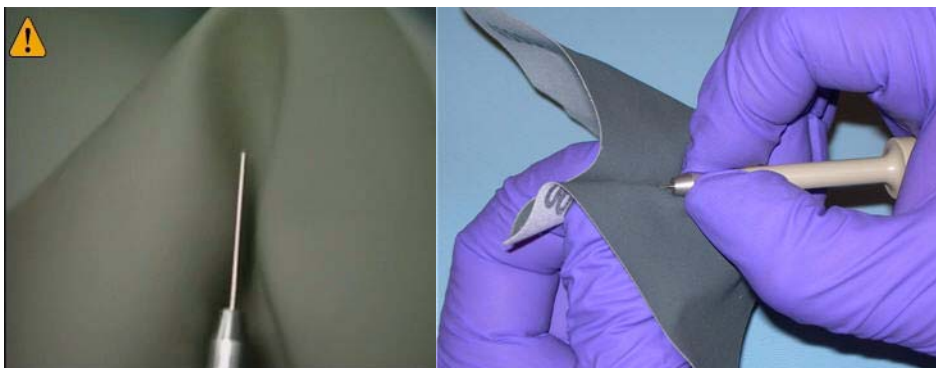

Figure 32 Pulling and twisting abrasive paper along the tip of the needle.

CAUTION

Do not bend or blunt the tip of the needle, or it will decrease system performance. Sharpening the needle is not necessary.

- 4 Repeat [step 2](#) and [step 3](#) several times, or until the needle looks clean and shiny.
- 5 Starting at the base of the needle, wipe the needle with a clean cloth. The cloth can be dry or dampened with isopropanol.



Figure 33 APCI corona needle after cleaning.

- 6 Reinstall the corona needle assembly in the spray chamber.

To replace the corona needle

CAUTION

Do not hit the tip of the needle against anything. It will bend the tip which will decrease system performance.

If this procedure fails to restore system performance, replace the corona needle.

When required When symptoms indicate poor corona needle performance and cleaning the needle does not restore performance.

Tools required

- Cloths, clean, lint-free (p/n 05980-60051)
- Gloves, clean
- Isopropanol, reagent grade or better

Parts required Corona needle (p/n G2429A)

1 Pull the corona needle assembly out of the spray chamber.

WARNING

The needle and related parts get very hot during operation. Make sure they have cooled before proceeding.

2 Unscrew the needle collar from the corona needle shaft.

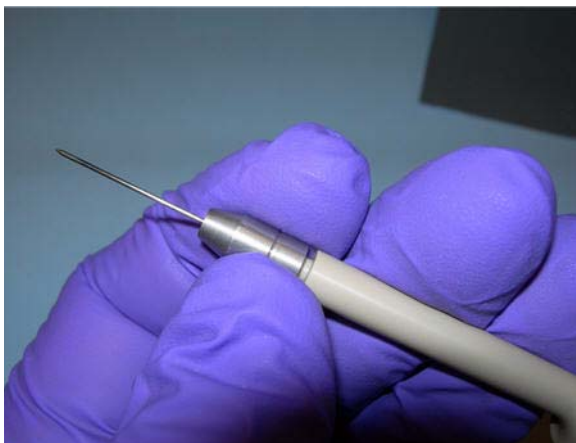

Figure 34 Unscrew the corona needle from the shaft.

2 Maintenance

To replace the corona needle

- 3 Remove the old corona needle from the collar.
- 4 Install a new needle, with its integral ferrule, in the collar.

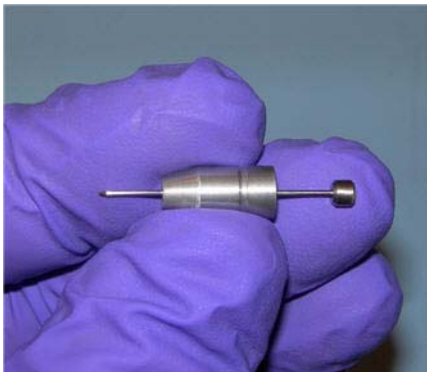

Figure 35 Replace the APCI corona needle.

- 5 Turn the collar onto the needle holder and tighten by hand.
- 6 Reinstall the corona needle assembly in the spray chamber.

CAUTION

Do not hit the tip of the needle against anything. It will bend the tip which will decrease system performance.

NOTE

Record this procedure in the Maintenance Logbook.

Multimode Source and HPLC-Chip/MS Interface

This section describes how to clean and adjust the multimode source and maintain the HPLC-Chip/MS interface.

To clean the multimode source daily

When required Daily or anytime you suspect carryover contamination from one sample or analysis to another, or when you must access the end cap and capillary cap for cleaning and inspection.

Tools required

- Gloves
- Wash bottle, clean

Parts required

- Abrasive paper, 4000 grit (p/n 8660-0827)
- Cloths, clean, lint-free (p/n 05980-60051)
- Cotton swabs (p/n 5080-5400)
- Mobile phase from the current method *or* clean isopropanol, reagent grade or better
- Water, reagent-grade or better

1 Turn off the spray chamber, nebulizer pressure, drying gas flow, drying gas temp, and vaporizer temp.

WARNING

Do not touch the multimode source or the capillary cap. They may be very hot. Allow the multimode source to cool down before you handle them.

2 Remove the nebulizer and the APCI corona needle.

3 Open the spray chamber.

4 Rinse the interior of the spray chamber using the wash bottle filled with the current mobile phase or with a mixture of isopropanol and water.

2 Maintenance

To clean the multimode source daily

NOTE

Recent residue should be soluble in the mobile phase. If you are not sure what mobile phase was used recently, a solution of 50% isopropanol and 50% water works well as a general cleaning solution.

WARNING

Some mobile phase are hazardous chemicals. Use the degree of caution appropriate for the mobile phase being used.

5 Wipe the interior of the spray chamber with a clean, lint-free cloth.

WARNING

Sharp edges can be found inside the spray chamber, such as the separator. Pay close attention when wiping the interior of the spray chamber.

6 Rinse the area around the spray shield. Do not spray directly toward the tip of the capillary. This can cause pressure surges in the vacuum system.

7 Dampen a clean cloth with the mobile phase. Wipe the spray shield, field shaping electrodes and the area around the spray shield.

8 Replace the nebulizer and the APCI corona needle.

9 Close the spray chamber.

NOTE

Use the weekly cleaning process if symptoms of contamination persist, or if the spray shield or capillary cap show significant discoloration that can not be removed by the normal daily cleaning procedure.

To clean the multimode source weekly

The cleaning procedure for cleaning the multimode source weekly is similar to the daily procedure. The main difference is that the multimode source is removed from the instrument in the weekly procedure.

When required Weekly if the normal daily cleaning procedure is not sufficient

Tools required

- Gloves
- Wash bottle, clean

Parts required

- Abrasive paper, 4000 grit (p/n 8660-0827)
- Cloths, clean, lint-free (p/n 05980-60051)
- Cotton swabs (p/n 5080-5400)
- Mobile phase from the current method *or* clean isopropanol, reagent grade or better
- Water, reagent-grade or better

- 1 Remove the multimode source.
- 2 Rinse out the spray chamber with clean mobile phase, or with a mixture of isopropanol and water.

NOTE

Recent residue should be soluble in the mobile phase. If you are not sure what mobile phase was used recently, a solution of 50% isopropanol and 50% water works well as a general cleaning solution.

WARNING

Some mobile phase are hazardous chemicals. Use the degree of caution appropriate for the mobile phase being used.

- 3 Scrub the corona insulator and the interior of the spray chamber with a clean cotton swab.
- 4 Wipe the interior of the spray chamber with a clean, lint-free cloth

WARNING

Sharp edges can be found inside the spray chamber, such as the separator. Be careful when wiping the interior of the spray chamber.

2 Maintenance

To clean the multimode source weekly

- 5 Remove the spray shield. Use abrasive paper to gently clean the end of the capillary cap.
- 6 Dampen a clean cloth and wipe the end of the capillary cap.
- 7 Reinstall the spray chamber.
- 8 Use abrasive paper to gently clean the spray shield. Dampen a clean cloth and wipe the spray shield.
- 9 Rinse the area around the spray shield then wipe the area around the spray shield.
- 10 Reinstall the spray chamber on the instrument.
- 11 Replace the nebulizer and APCI corona needle.
- 12 Install the thermocouple probe and adjust it so that it protrudes 15mm from the inner spray chamber wall.
- 13 Close the spray chamber.

Refer to the *Agilent G1978A/B Multimode Source Maintenance Guide* (p/n G1978-90040) for future cleaning of the charging electrode assembly.

To adjust the multimode nebulizer

When required When the needle is plugged. Common symptoms of a plugged needle are increased LC back pressure or off-axis spraying or dripping from the nebulizer.

- Tools required**
- Adjustment fixture (p/n G1946-20215)
 - Gloves, clean
 - Pliers, long nose (p/n 7810-0004)
 - Wrench 3-mm, open-end (p/n 8710-2699)
 - Wrench ¼-inch x 5/16-inch, open-end (p/n 8710-0510)

Parts required Nebulizer needle kit, Electrospray (includes needle, ferrule, and needle holder, p/n G2427A)



Figure 36 Electro spray nebulizer needle in needle holder

- 1 Install the nebulizer in the adjustment fixture.
- 2 Loosen the locknut next to the zero-dead-volume (ZDV) union.
- 3 Remove the union from the nebulizer.
- 4 Loosen the locknut of the needle holder.
- 5 Unscrew the needle holder and pull it out of the nebulizer.
- 6 Slide the non-tapered end of the needle through the new needle holder from the narrower side.

2 Maintenance

To adjust the multimode nebulizer

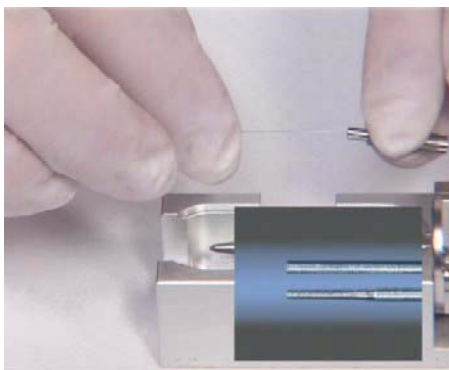

Figure 37 Sliding the non-tapered end of the needle through the new needle holder

- 7 Push a new ferrule, flat-side first, onto the needle.
- 8 Be sure the needle does not extend from the ferrule.
- 9 Reinstall the locknut and the union. Hand tighten the union.
- 10 Hold the needle holder steady with a 3-mm wrench. Tighten the union one-quarter to one-half turn to compress the ferrule.



Figure 38 Tightening the union screw to compress the ferrule

- 11 Tighten the locknut against the union.
- 12 Pull carefully on the needle to ensure the needle is held firmly in place.
- 13 Replace locknut and washer.
- 14 Insert the needle into the nebulizer shaft.

CAUTION

Take care when inserting the needle. The tapered end of the needle must pass through the restrictions in the nebulizer shaft. The tip of the needle can be damaged if excessive force is applied.

15 Adjust the electrospray needle position before reinstalling the nebulizer in the spray chamber.

NOTE

Record this procedure in the Maintenance Logbook.

2 Maintenance

To change HPLC-Chip capillaries

To change HPLC-Chip capillaries

When When broken, blocked or kinked

Tools Required

- Cube wrench (p/n G4240-83800)
- Hex key 3 mm, 12-cm long (p/n 8710-2411)

Parts List

- Fused silica/PEEK capillary (see Parts)

1 Unload the HPLC-Chip

CAUTION

Do this procedure only if the TOF LC/MS is mounted on the MS or is sitting flat on a table because the center of gravity shifts and the instrument will tip over without adequate support.

2 Press the cover release button once. When the lock opens pull the front panel down.

3 Unlock the stages assembly and flip it out.

4 Remove the capillary cover (A) and open the thumb screw of the strain relief (B). See [Figure 39](#).

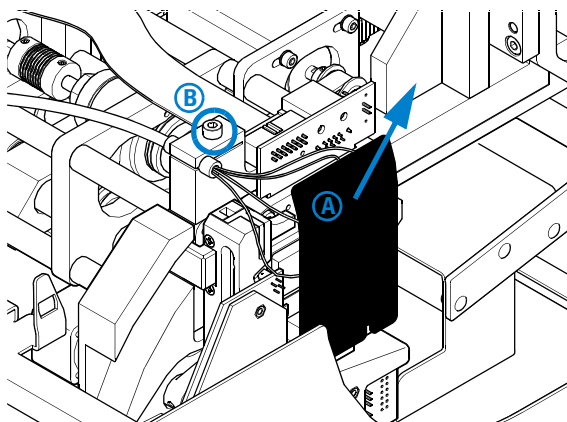

Figure 39

- 5 Loosen the slotted PEEK fitting using the Cube wrench and pull the capillary out. See [Figure 40](#).

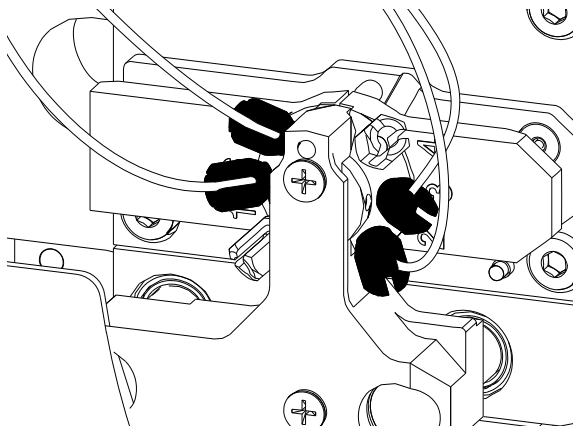

Figure 40

- 6 Push the new capillary through the capillary guide until the stopper is flush with the end of the guide tube. Tighten the thumb screw firmly.
The strain relief will only function properly if all 4 capillaries are in place.

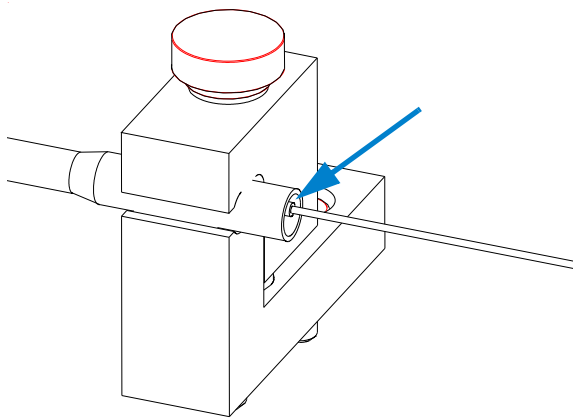

Figure 41

2 Maintenance

To change HPLC-Chip capillaries

7 Connect the capillaries as follows to the HPLC-Chip valve stator:

For forward-flush mode (default)

- port 1 - not used
- port 2 - 15 μm (orange) to nanopump
- port 3 - 75 μm (blue) to infusion pump
- port 4 - not used
- port 5 - 100 μm (black) to waste
- port 6 - 25 μm (yellow) to port 6 of the μ -WPS

For backflush mode

- port 1 - not used
- port 2 - 15 μm (orange) to nanopump
- port 3 - 75 μm (blue) to infusion pump
- port 4 - not used
- port 5 - 25 μm (yellow) to port 6 of the μ -WPS
- port 6 - 100 μm (black) to waste

8 Route the capillaries exactly as shown in [Figure 42](#).

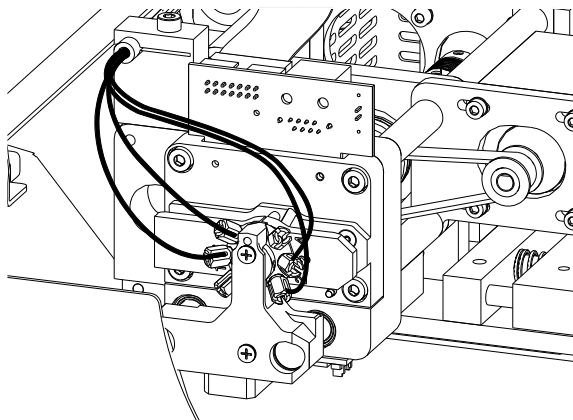

Figure 42

9 Reinstall the capillary cover. Do not overtighten the cover screws!

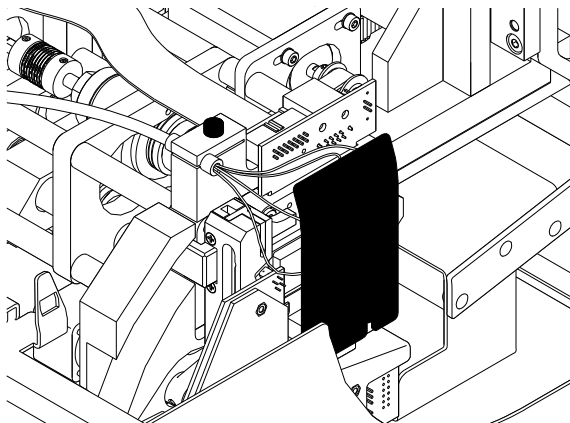

Figure 43

10 Flip the stages assembly up and close the front pane.

Ion Transfer Capillary

This section describes the steps to remove, clean and reinstall the ion transfer capillary.

To remove the capillary

When required	When you need to clean or replace the capillary.
Tools required	Gloves, clean
Parts required	None

- 1 Vent the system.
- 2 Unplug the instrument power cord from the power outlet after venting is complete.
- 3 Open the spray chamber.

WARNING

The spray chamber operates at very high temperatures. Give the spray chamber time to cool before proceeding.

-
- 4 Remove the spray shield.
 - 5 Remove the capillary cap from the end of the capillary.
 - 6 Carefully with a rotational motion, pull the capillary out of the desolvation assembly.



Figure 44 Pulling the capillary out of the desolvation assembly

CAUTION

Carefully with a rotational motion, pull the capillary out along its long axis. The capillary is glass or of similar material, and you can break it by putting vertical or horizontal pressure on it.

2 Maintenance

To clean the capillary

To clean the capillary

When required When you observe decreased sensitivity and decreased signal stability

Tools required

- 5190-1401 Cleaning Powder, Dielectric Capillary
- 100mL polypropylene graduated cylinder, or glass-graduated cylinder with two 1 mL pipette tip

Parts required Powdered Precision Cleaner (Alconox catalog number 1104)

- 1 Dissolve 1 g Alconox Powdered Precision Cleaner in 100 mL deionized water.

This concentration is the recommended concentration for “manual or ultrasonic cleaning”.

- 2 Place the ion transport capillary upright in a 100 mL polypropylene graduated cylinder and fill with Alconox solution.
- 3 Sonicate the graduated cylinder with the ion transport capillary in an ultrasonic cleaner for 10 to 15 minutes.



You may use a 1 mL pipette over the end of the ion transport capillary to protect the metallized plating. Trim the pipette tip to approximately 4 cm so that the capillary can be immersed in the cleaning solution.



To maintain proper cleanliness, handle the ion transport capillaries with protective gloves.

- 4 Rinse the ion transport capillary and graduated cylinder several times with deionized water.
- 5 Fill the graduated cylinder with deionized water and sonicate the graduated cylinder with the ion transport capillary for 10 to 15 minutes.
- 6 Remove the ion transport capillary from the graduated cylinder and remove the pipette tip (if one was used).
- 7 Blow out excess water from the ion transport capillary bore using AeroDuster or oil-free pressurized gas.
- 8 Install the ion transport capillary in LC/MS Desolvation Assembly:
 - a Lubricate the ion transport capillary surface with isopropanol and insert carefully into Desolvation Assembly. Support the front and rear of the capillary and keep it level during installation.

When 2 to 3 cm of the capillary remains extended from the Desolvation Assembly, the capillary will “hold up” on the rear contact spring. Continue to apply pressure until approximately 1 cm remains extended from the Desolvation Assembly.

- b Lubricate the ion transport capillary tip with isopropanol and install the Capillary Cap.
- c Install the threaded Spray Shield by turning clockwise.

2 Maintenance

To clean the capillary

9 Close the spray chamber and begin an instrument pump down.

NOTE

If a new capillary was installed, record this procedure in the Maintenance Logbook.

To reinstall the capillary

When required After cleaning the capillary or when installing a new capillary.

Tools required Gloves, clean

Parts required Isopropanol, HPLC grade or better

- 1 Lubricate the capillary entrance end with isopropanol.
- 2 Slide the capillary out with rotational motion into the desolvation assembly. The capillary must be aligned correctly so that its end will fit into a fixed capillary cap inside the desolvation assembly.



Figure 45 Reinstalling the capillary

CAUTION

Putting vertical or horizontal pressure on the capillary can break it.

- 3 Reinstall the capillary cap over the outer end of the capillary.
- 4 Reinstall the spray shield.
- 5 Close the spray chamber.

Calibrant Delivery System and Divert Valve

This section describes maintenance tasks that are related to the calibrant delivery system and divert valve.

When you do maintenance procedures on the divert valve:

- Check drain bottle in shorter intervals as usual!
- Do not bend any capillary line.
- The position of the divert valve can be set only in the On mode.
- Put the instrument in the Off mode.
- Remove the covers before you begin.
- Install the covers of the instrument after you finish.

Table 1 Divert Valve Connection (see [Figure 46](#))

No.	Port	Connection	User action
1	Inlet	from the front inlet union behind the inlet cover	none
2	Inlet	from CDS	none (permanent connection from calibrant delivery system)
3	Outlet	to the ion source	connect the flexible capillary to the ion source
4	Loop	loop to port 6	none (permanent connection)
5	Waste	to the drain bottle	none
6	Loop	loop to port 4	none (permanent connected)

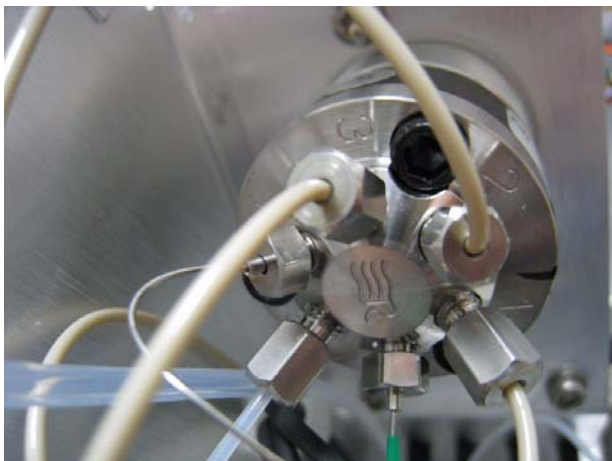

Figure 46 Divert valve with port position indicators

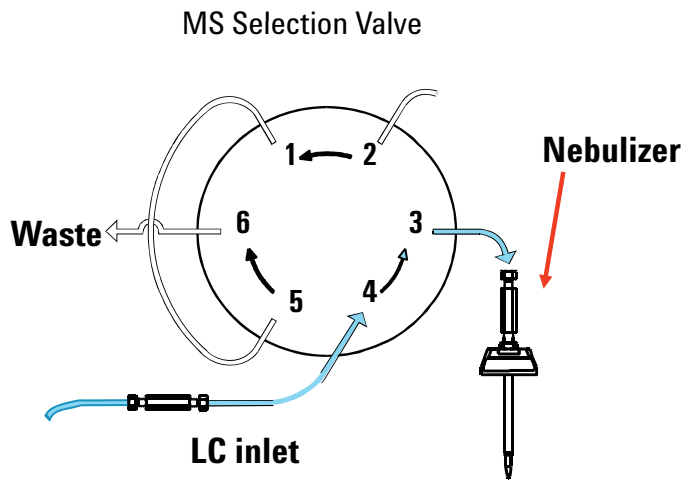

Figure 47 LC to LC/MS flow

2 Maintenance
Calibrant Delivery System and Divert Valve

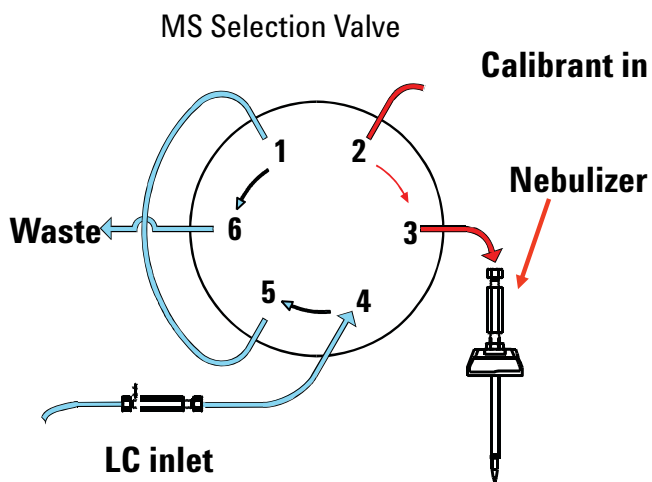

Figure 48 Calibrant to LC/MS flow

To check calibrant levels

When required Monthly or weekly if you tune the instrument frequently

Tools required None

Parts required None

- 1 Examine each calibrant bottle. Enough tuning mix must be present to immerse the end of the intake tube.
- 2 If the tuning mix level is within a few millimeters of the end of the intake tube, refill the calibrant bottle.

NOTE

Record this procedure in the Maintenance Logbook.

2 Maintenance

To fill a tuning mix or reference mix bottle

To fill a tuning mix or reference mix bottle

When required As necessary.

Tools required None

Parts required

- APCI-L Tuning Mix (p/n G1969-85010)
- ESI-L Tuning Mix (p/n G1969-85000)
- MMI-L Tuning Mix (p/n G1969-85020)
- Reference Mix (created from G1969-85001 Reference Mass Kit)

The 6230 with Agilent Jet Stream Technology uses the ESI-L Tuning Mix.

- 1 Turn the bottle to be refilled clockwise until it can be removed from the fixed bottle cap.
- 2 Refill the bottle with the appropriate tuning mix.
- 3 Put the intake tube into the refilled bottle as you lift the bottle into position.
- 4 Attach the calibrant bottle onto the fixed bottle cap. Turn the bottle counterclockwise to tighten.

CAUTION

Tighten the bottle by hand. Do not overtighten it. The bottle only needs to be snug.

NOTE

Record this procedure in the Maintenance Logbook.

The tuning mixes are not interchangeable, even though they will give similar mass spectra. Failure to change the tuning mix when the source or inlet assembly is changed can result in miscalibration of the instrument and erroneous mass assignments.

To check for leaks

When required When the sensor indicates a leak has occurred.

Tools required

- Cloths, clean, lint-free (p/n 05980-60051)
- Cotton swabs (p/n 5080-5400)
- Screwdriver, TORX, T-10 (p/n 8710-1623)

Parts required None

- 1 Remove the front cover from the instrument.
- 2 Remove the calibrant bottles.
- 3 Turn off the Spray Chamber nebulizer pressure, drying gas temp, and vaporizer temp (for APCI or multimode).

WARNING

The spray chamber operates at very high temperatures. Do not touch any parts inside the chamber until they have had time to cool.

- 4 Loosen the two thumb screws on CDS to access catch tray.
- 5 Check the catch tray. If you see liquid, the pump has a leak. If no liquid is present, the leak sensor may be out of calibration. See the online Help for instructions to calibrate the leak sensor.
- 6 If a leak occurs during a long unattended run, the liquid from the leak may evaporate to give you the impression that no leak exists and the leak sensor is out of calibration. Turn the system back on and make sure no leak exists before you recalibrate the leak sensor.
- 7 Check the selection valve, the waste fitting, the inlet fitting, and the calibrant delivery system valves. If you find a leak, correct it and check the remaining locations.
- 8 Dry the catch tray and leak sensor.
- 9 When the catch tray and leak sensor are thoroughly dry, reassemble the instrument.

2 Maintenance

To replace the LC filter elements

To replace the LC filter elements

When required When back pressure is high on the LC pump or when the sensor indicates a leak has occurred.

Tools required

- Tweezers
- Wrench, ½-inch

Parts required Filter Element, 5 µm (p/n 0100-2051)

- 1 Stop the flow of LC solvent to the instrument.
- 2 Remove the front and top covers.
- 3 Turn off the spray chamber nebulizer pressure, drying gas temp, and vaporizer temp (if APCI or multimode).
- 4 Remove the spray chamber.
- 5 Remove the upper left front cover to access the inlet filter assembly.

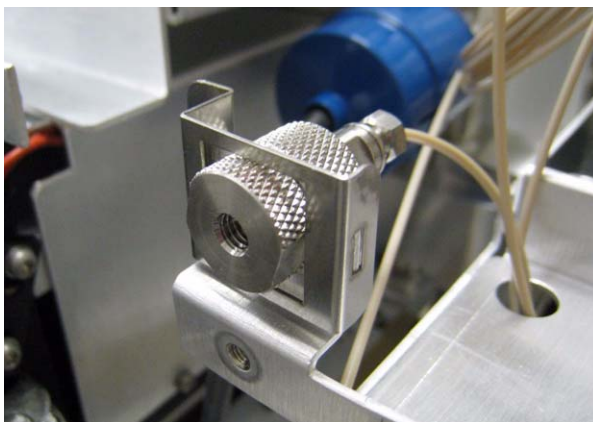

Figure 49 Inlet filter assembly

- 6 Remove the retaining screw at the top of the inlet filter assembly and pull the filter assembly forward out of the bracket.
- 7 While holding the knurled lower part of the assembly, twist the upper part counterclockwise until the two parts are separated.

To replace the MS selection valve rotor seal

- 8 Use tweezers to remove the filter element from the upper part of the assembly. The filter element is a stainless steel frit surrounded by a Teflon ring.
- 9 Insert the new filter element.
- 10 Reassemble the filter assembly.
- 11 Reinsert the assembly into the bracket and reinstall the top retaining screw.
- 12 Reinstall the covers and spray chamber.

To replace the MS selection valve rotor seal

When required Approximately annually or when no calibrant flow exists during tuning, or when the back pressure is high on the LC pump during acquisition.

Tools required Hex key wrench

Parts required Rotor seal (p/n 0100-1855)

- 1 Stop the flow of LC solvent to the instrument.
- 2 Remove the front cover.
- 3 Remove the top cover.
- 4 Remove the left side cover.
- 5 Remove the tubing connections from the six-port MS selection valve.

2 Maintenance

To replace the MS selection valve rotor seal

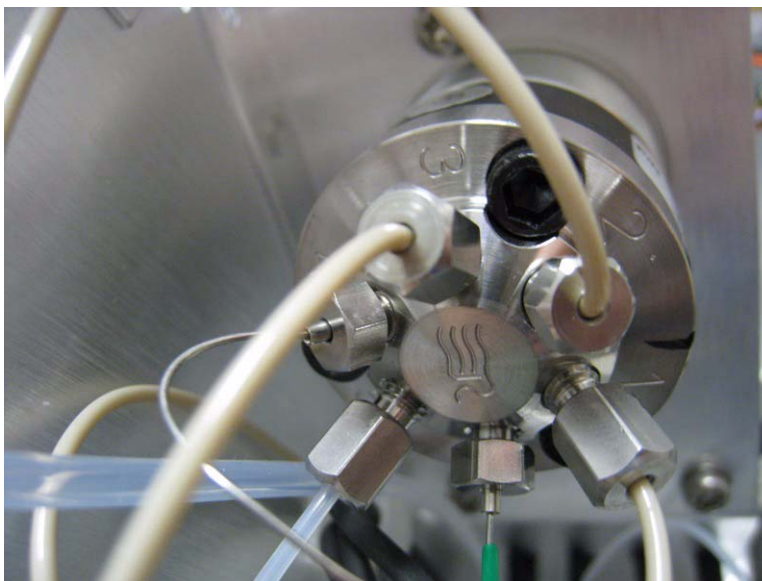

Figure 50 Six-port MS selection valve

- 6** Use the hex key wrench to remove the three hex head screws from the stator face of the selection valve.
- 7** Remove the rotor seal and replace it with a new one. Be sure to install it in the proper orientation.
- 8** Reinstall the stator face assembly.
- 9** Reconnect the tubing to the selection valve.
- 10** Reinstall the left, top and front covers.

Manifold

This section describes how to open and close the manifold, and to clean the ion optics assembly.

To open the manifold

When required	As necessary for maintenance.
Tools required	None
Parts required	None

- 1 Vent the system.
- 2 Unplug the instrument power cord from the power outlet after venting is complete.
- 3 Remove the front cover from the instrument.
- 4 Remove the top cover from the instrument.
- 5 Remove the left side covers.
- 6 Disconnect the connections to the Aux module, and lift off and remove the Aux module. Put on an antistatic wrist strap. Attach the wrist strap to a grounded surface such as the back panel of the instrument.
- 7 Remove the two thumb screws and two T-20 flat head screws.
- 8 Lift off the vacuum manifold cover.

2 Maintenance

To close the manifold

To close the manifold

When required As necessary after manifold maintenance.

Tools required None

Parts required None

NOTE

If you worked on any components in the manifold, check to be sure the electrical connections are correct before closing the manifold.

- 1 Position the manifold cover on the vacuum manifold.
- 2 Reinstall the top cover of the instrument.
- 3 Reinstall the Aux module on to the top of the vacuum manifold.
- 4 Reconnect the connections to the Aux module.
- 5 Reinstall the left side covers. Reinstall the front cover of the instrument.
- 6 Pump down the instrument.

To disassemble and clean the complete ion optics assembly

CAUTION

This procedure is to be done by an Agilent-trained Service Engineer only. Agilent assumes no responsibility for damages if someone other than an Agilent-trained Service Engineer attempts these steps.

When required When determined by an Agilent-trained Service Engineer to be absolutely necessary.

- Tools required**
- Gloves, clean
 - Cloths, clean, lint-free (p/n 05980-60051)
 - Beakers, 500 ml, 2 ea
 - Tweezers
 - Screwdriver, TORX, T-10 (p/n 8710-1623)
 - Ball driver, 1.5 mm (p/n 8710-1570)
 - Methanol, reagent grade or better
 - Isopropanol, reagent grade or better
 - Acetone, reagent grade or better

Parts required None

- 1 Vent the instrument. Wait for the foreline vacuum to reach 760 torr or close to it. Make sure the turbo speed is at or close to zero.
- 2 Turn the front power switch off
- 3 Remove covers:
 - a Remove the front cover and disconnect the status panel ribbon cable.
 - b Remove the top cover. Remove the single screw torx T15 in front and the two torx T15 screws in back.
 - c Remove the cosmetic cover behind the spray chamber cover. Remove the four torx T10 screws.
- 4 Remove connections:
 - a Remove nebulizer peak tubing connection.
 - b Remove the Reference IRM peak tubing connection to the desolvation assembly.

2 Maintenance

To disassemble and clean the complete ion optics assembly

- c** Remove the reference gas connection to the Agilent Jet Stream inlet assembly from the reference gas supply.
 - d** Remove nebulizer the gas connection from nebulizer gas supply.
 - e** Remove the Vaporizer Heater connection the Agilent Jet Stream inlet assembly.
 - f** Remove the multimode corona connection to the auxiliary module, used for Agilent Jet Stream inlet assembly nozzle voltage.
- 5** Unlatch the Agilent Jet Stream inlet assembly and swing open the door.
- 6** Remove the desolvation assembly:
- a** Lift the ESI with Agilent Jet Stream inlet assembly off if the dowel hinges, place the storage cover on Agilent Jet stream and set aside.
 - b** Remove the back heater connection from the left side of the desolvation chamber left side.
 - c** Remove the nitrogen gas connection on desolvation assembly. Use the 9/16-inch wrench and the 1/2-inch wrench to hold the 1/2-inch nut on the opposite side.
 - d** Remove the exhaust hose from the desolvation assembly. Use the flat head screw driver to remove the clamp on the corrugated exhaust hose.
 - e** Remove the status, diverter valve, and CDS cables from the auxiliary module.
 - f** Remove the capillary and chamber voltage connection from the auxiliary module.
 - g** Remove the main board connection to the auxiliary module.
 - h** Remove thumb screw from the front of the auxiliary module.
 - i** Loosen the two T10 screws bottom of the APCI power supply bracket. Do not remove the screws. Lift the auxiliary module up and off the manifold cover.

To disassemble and clean the complete ion optics assembly

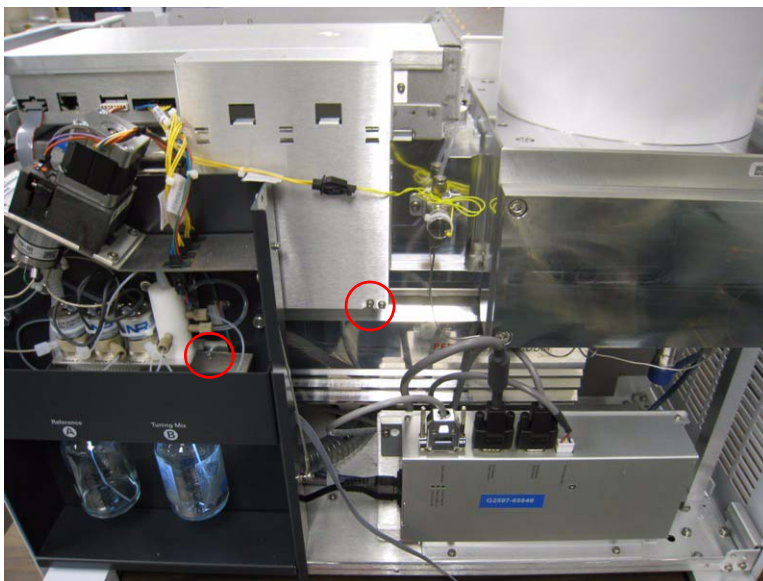

Figure 51 Loosen the screws that are circled.

- j Remove the two T20-torx screws that hold the desolvation assembly at the upper left and bottom right to the vacuum manifold.

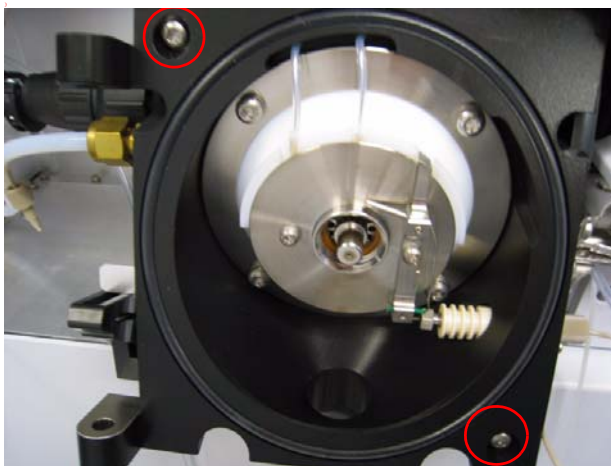

Figure 52 Remove circled screws

To disassemble and clean the complete ion optics assembly

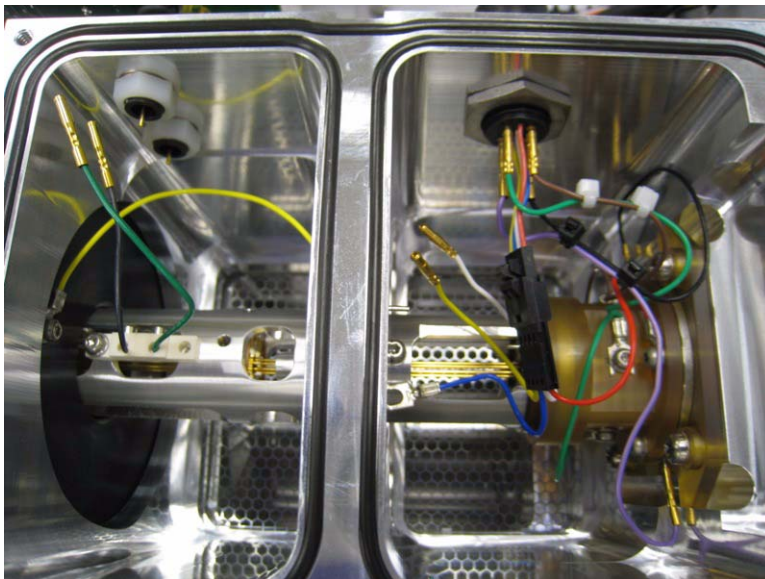

Figure 54 Optics assembly, all cables disconnected.

- 9 Press on the skimmer spacer with your right hand fingers while you hold the skimmer side with your left hand. This prevents the Ion Optics assembly from falling on the floor when it pops loose.

2 Maintenance

To disassemble and clean the complete ion optics assembly

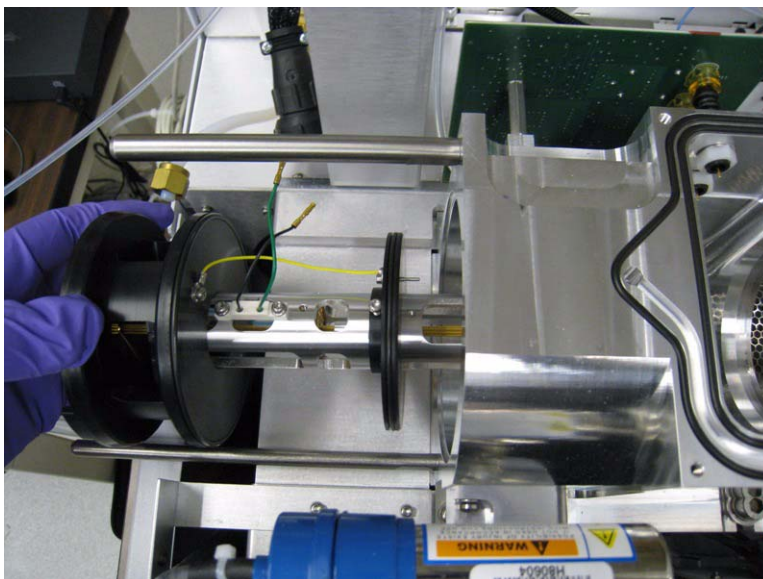

Figure 55

10 Place the complete ion optic assembly under a fume hood on clean cloths.

11 Put the manifold cover back on to keep dust out while you clean the ion optics.

To disassemble and clean the complete ion optics assembly

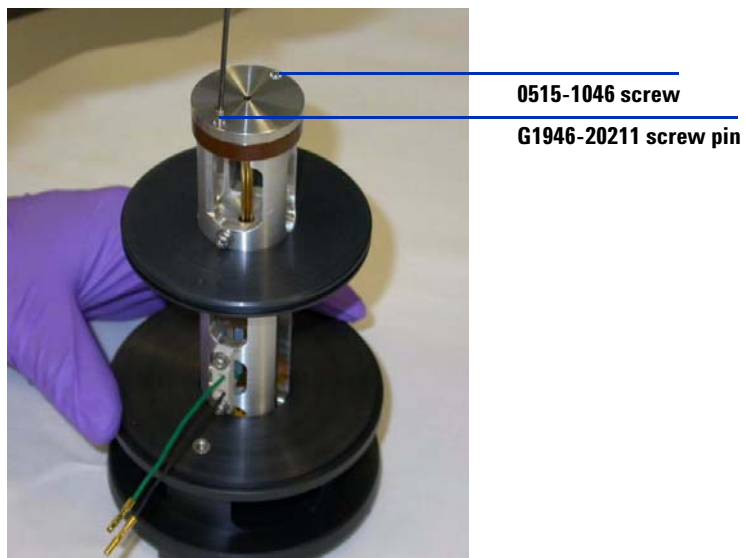

Figure 56 Ion focus lens removal

12 Remove the two Torx T6 screws on the ion focus ions.

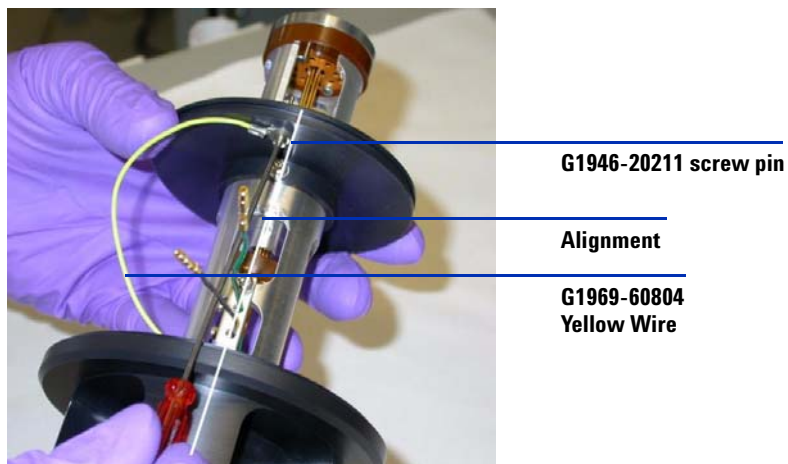

Figure 57

13 Remove the skimmer O-ring and partition O-ring, then turn on the ion optic on its side and remove the two skimmer Torx T10 screws.

2 Maintenance

To disassemble and clean the complete ion optics assembly

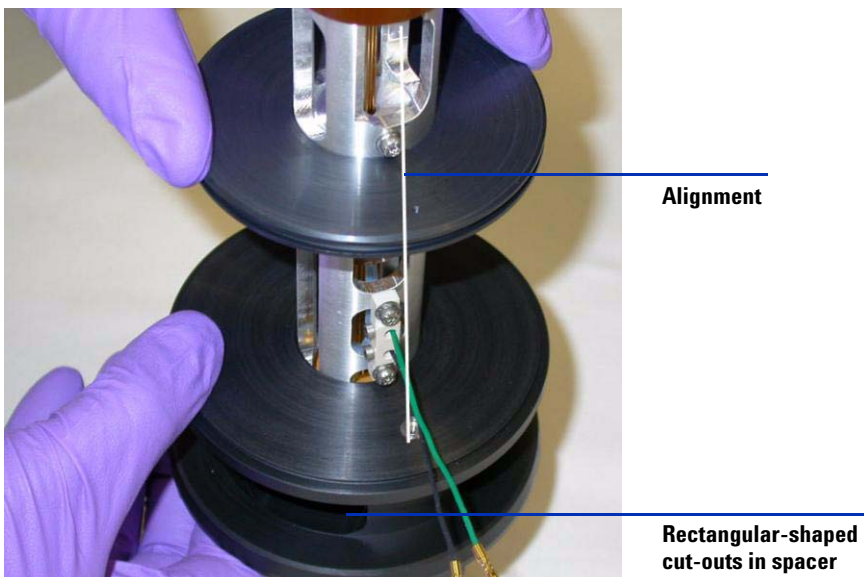

Figure 58 Reference on alignment of the ion optics assembly partition and skimmer spacer if skimmer spacer is removed. Note the skimmer spacer can be removed to better clean octopole rods but is not recommended. The skimmer spacer can damage the octopole rods when you try to put it back on.

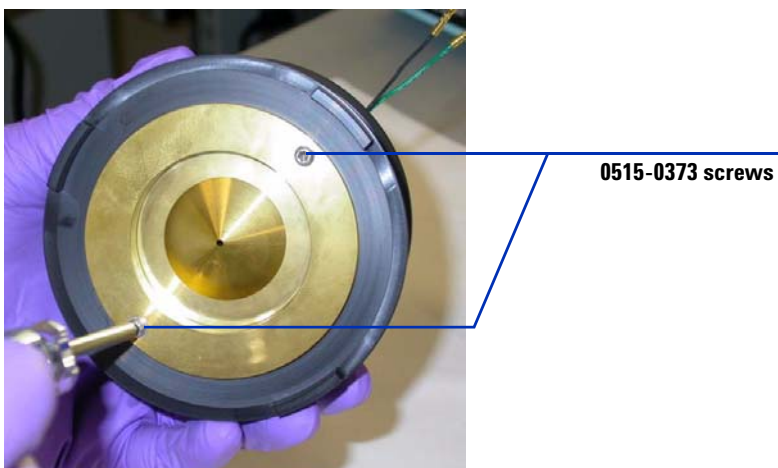
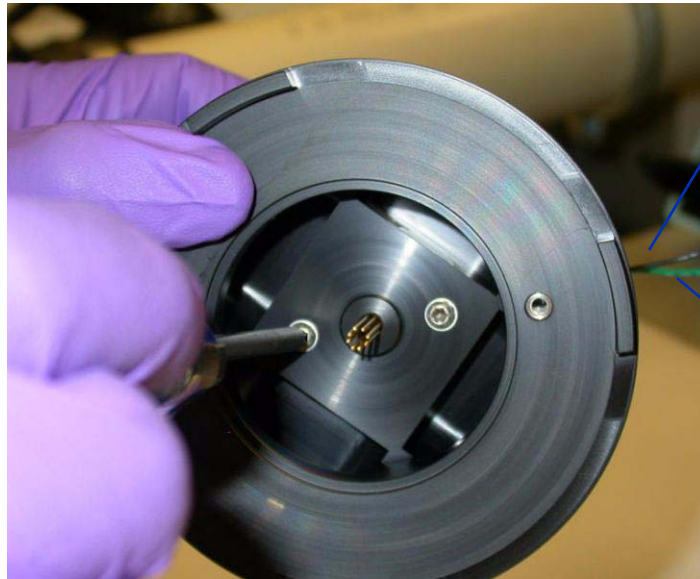

Figure 59 Skimmer O-ring and partition O-ring removed

To disassemble and clean the complete ion optics assembly



Align the Strain Relief Block/Wires with the extended area on the bottom of the skimmer spacer.

These wires must align with the foot on the spacer.

Figure 60 Remove these two screws (p/n 0515-0372) to remove the skimmer for better access to the rods for cleaning.

14 Remove the skimmer and skimmer O-ring.

The skimmer may be hard to separate from the skimmer spacer. You can use one finger inserted into the skimmer space cutout to push on the opposite side of the skimmer to help pop it loose.

CAUTION

Do not let your finger come in contact with the octopole rods, or you can damage the octopole rods.

CAUTION

Never disassemble Ion Optics 1 further than instructed here.

2 Maintenance

To disassemble and clean the complete ion optics assembly



Figure 61 Skimmer and ion focus removed for cleaning

- 15** Clean the skimmer and ion focus lens with deionized water and a very small amount of Alconox in a clean beaker. Use a clean tech wipes to clean all surfaces of the skimmer and ion focus lens.
- 16** Rinse both the skimmer and the ion focus lens. Be sure to rinse all Alconox off the parts.
- 17** Place both the skimmer and ion focus lens in clean beaker. Sonicate for 5 minutes. Pour out the isopropanol and refill the beaker with 100% acetone. Sonicate for another 5 minutes. Pour out the acetone and refill with 100% methanol. Sonicate for another 5 minutes.
- 18** Turn the ion optics assembly vertically over a container. Pour methanol down through the octopole rods to rinse the octopole rods. Let the octopole assembly rods dry for about 15 minutes or blow dry with clean nitrogen.
- 19** Reassemble the ion optics assembly:
 - a** Replace the ion focus lens on the octopole assembly with two Torx T6 screws.
 - b** Place the O-ring back on the skimmer.
 - c** Place the skimmer back on the skimmer spacer with two Torx T10 screws.
 - d** Place the partition O-ring back on the partition.
 - e** Place the skimmer spacer O-ring back on the skimmer spacer.

To disassemble and clean the complete ion optics assembly

- f Reinstall the ion optics into the vacuum manifold and reverse all disassembly procedures.
- g Test for continuity before installing. Check that Negative on Green Wire and Positive on Black Wire Readings are OL (over limit).



Figure 62 Testing for continuity.

Figure 63 shows the exploded view of the ion optics assembly.

2 Maintenance

To disassemble and clean the complete ion optics assembly

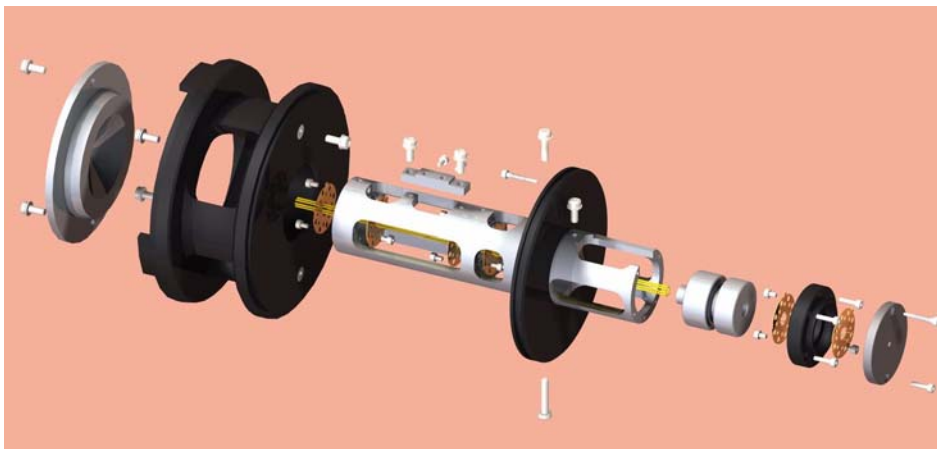

Figure 63 An exploded view of the ion optics assembly. Note that this picture is provided for reference only. The ion optics assembly is never to be disassembled to this level.

20 After reassembly of the ion optics assembly (see [Figure 64](#)), reinstall the ion optics assembly into the vacuum manifold. Connect the green and black octopole leads, and reconnect the lens cable connector.

To disassemble and clean the complete ion optics assembly

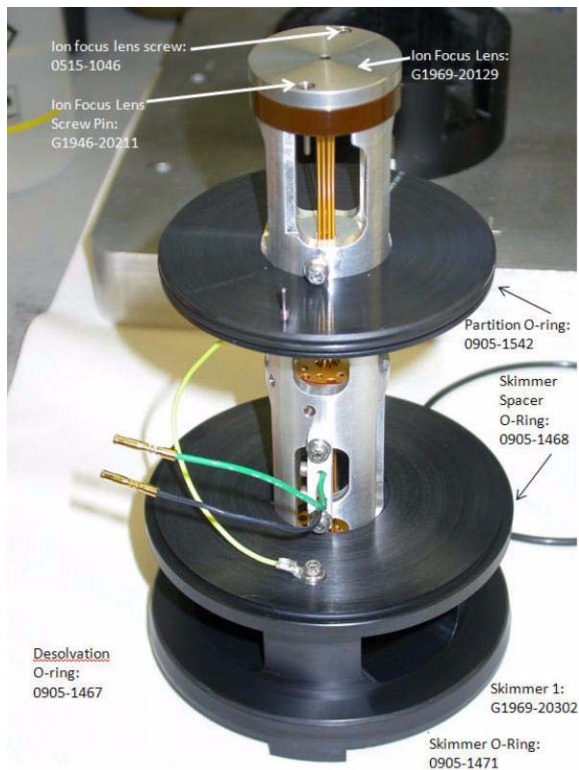

Figure 64 The re-assembled ion optics assembly

21 Reinstall the desolvation assembly onto the front of the vacuum manifold. Reinstall the Aux module onto the top of the vacuum manifold, and reconnect the connections to the Aux module. Reconnect the drying gas heater cable and the drying gas line to the side of the desolvation assembly.

2 Maintenance

To remove and clean the complete beam shaping assembly

To remove and clean the complete beam shaping assembly

CAUTION

This procedure is to be done by an Agilent-trained Service Engineer only. Agilent assumes no responsibility for damages if someone other than an Agilent-trained Service Engineer attempts these steps.

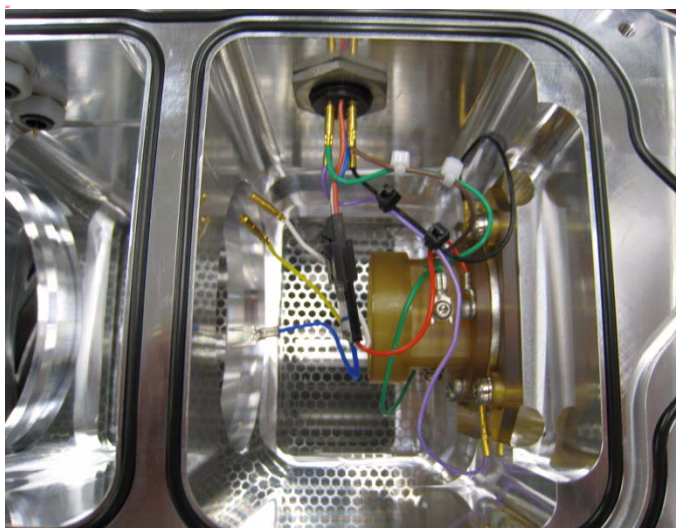

Figure 65

- 1 Remove the ion optics assembly. See [“To disassemble and clean the complete ion optics assembly”](#) on page 107. Follow [step 1](#) through [step 10](#).

If both the ion optics and beam shaping assemblies are going to be cleaned, do the steps in [“To disassemble and clean the complete ion optics assembly”](#) on page 107 through [step 19](#).

- 2 Disconnect the green and brown Horizontal Q and Vertical Q wire from the rear vacuum manifold cable harness feed-through.

To remove and clean the complete beam shaping assembly

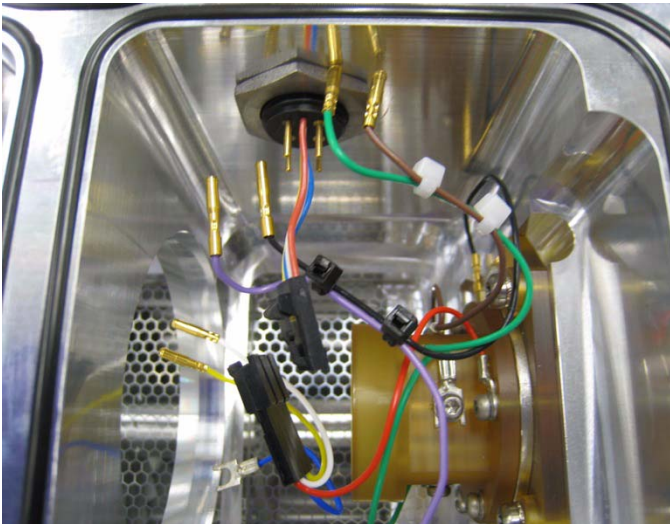

Figure 66

- 3 Disconnect the bottom left purple wire Top Slit and bottom right black wire Bottom Slit from the rear vacuum manifold cable harness feed through.
- 4 Disconnect the Black snap connector with the Red wire Slicer voltage, yellow Skimmer voltage, blue Octopole housing, and white Ion focus wires.

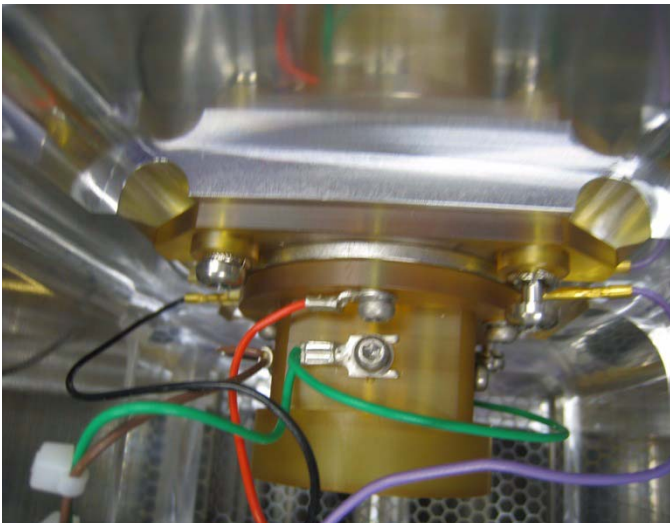

Figure 67

- 5 Use a pair of tweezers to remove the black wire bottom slit and purple wire top slit from the connections on the beam-shaper slicer assembly.
- 6 Remove the cable purple and black wire cable from the rear vacuum manifold and set it aside.

If these wires are not removed, the slicer assembly cannot be pulled through the vacuum manifold into the ion optics region and out the desolvation chamber attachment of the front manifold.

2 Maintenance

To remove and clean the complete beam shaping assembly

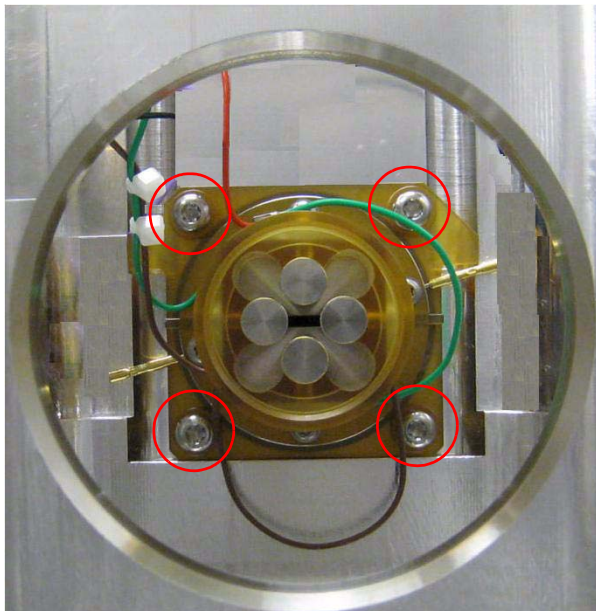

Figure 68 Loosen the four Torx screws (circled)

- 7 Loosen the four Torx T20 screws that hold the beam-shaping slicer assembly in place. Insert the Torx T20 driver from the front of the manifold.

The screws are capture type and will not fall after they are loosened.

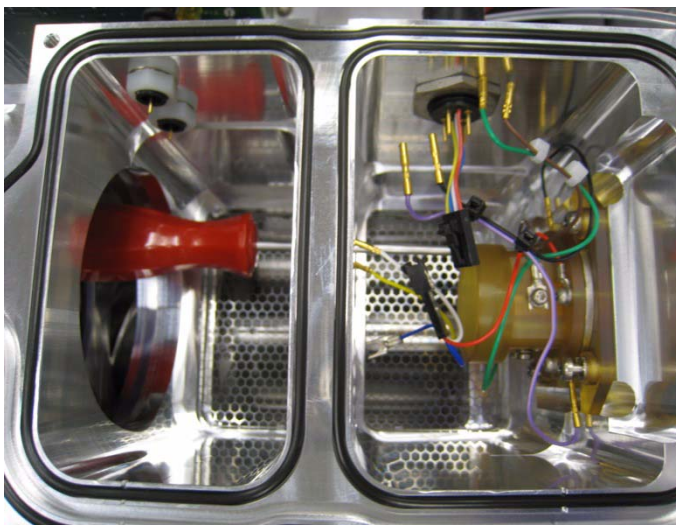

Figure 69

To remove and clean the complete beam shaping assembly

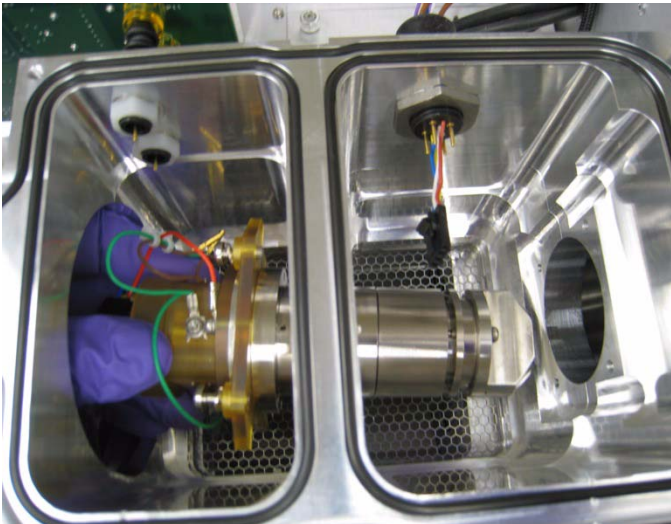

Figure 70

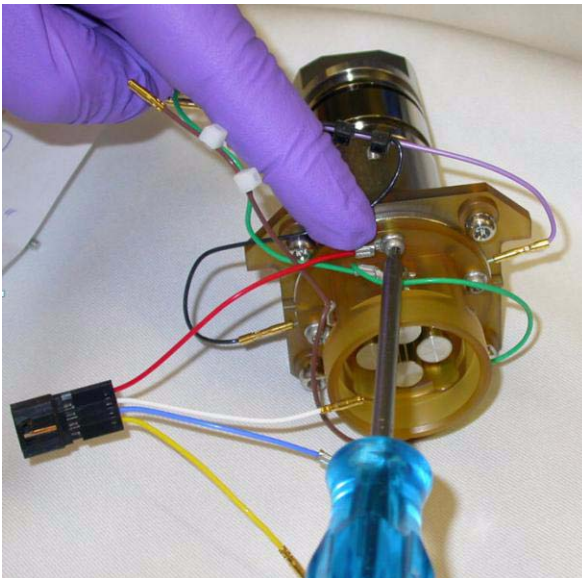

Figure 71

8 Remove the beam-shaping slicer assembly from the source side of the manifold.

9 Place the complete beam-shaping slicer assembly under a fume hood on clean cloths for disassembly and cleaning.

10 Inspect the correct wiring as shown in this picture. Remember that you removed the purple and black wire harness before you removed it from manifold.

11 Remove the red wire with black quick connector from the slicer housing.

2 Maintenance

To remove and clean the complete beam shaping assembly

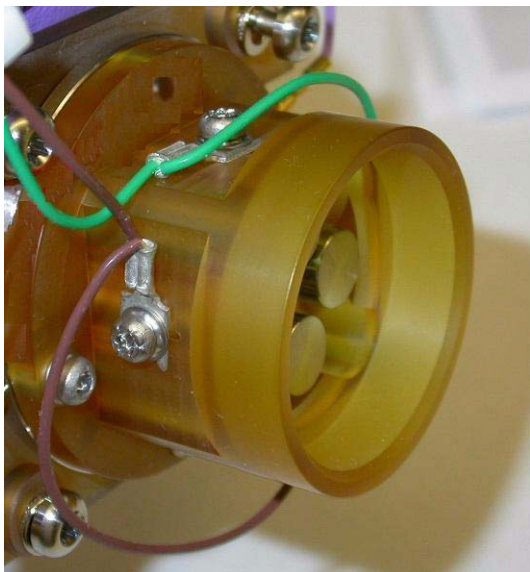

Figure 72

Figure 72 shows all wiring connections with the purple and back wire connected. Use this picture for reference when you reassemble the unit. You will reinstall the purple and black wire after the beam-shaping slicer assembly is placed back into the vacuum manifold.

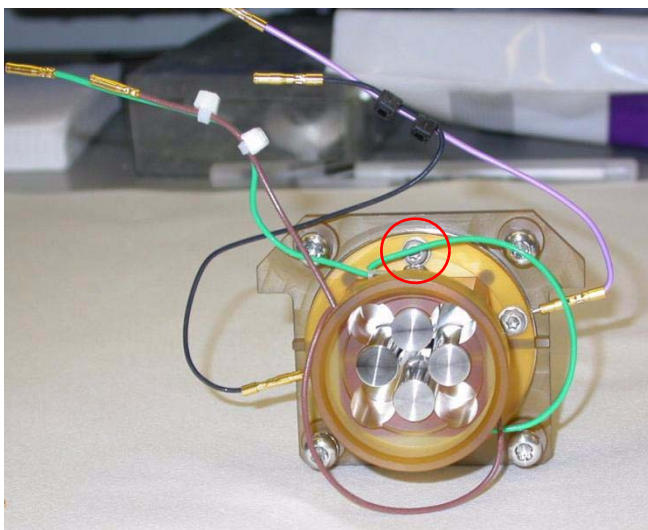

Figure 73 Note that the red slicer voltage current wire is removed from the circled screw.

Figure 73 shows the red slicer voltage current wire removed.

To remove and clean the complete beam shaping assembly

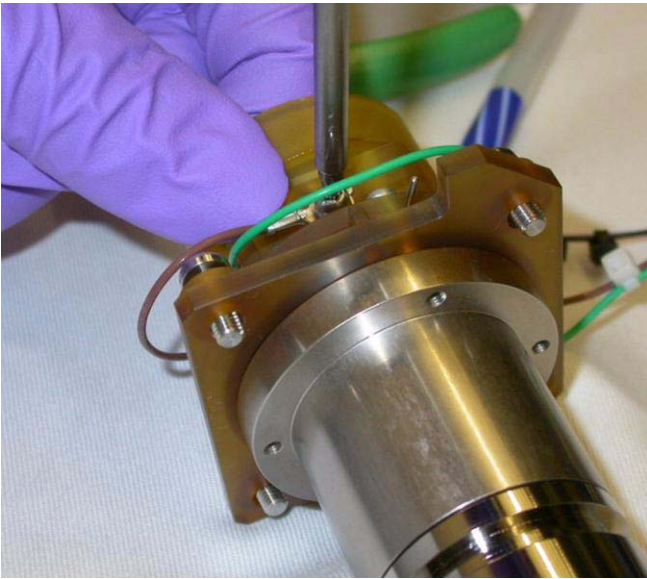

Figure 74

- 12** Loosen the two screws (p/n 0515-0372) that are attached to each two brown wire, then remove the brown wires that connect the (p/n G2597-60802) cable assembly to the “horizontal” P-filter quad rods. These wires are slotted so the P-filter rods can be left in place.

You can remove the P-filter rods, or leave them in the housing and just rinse them off with methanol.

- 13** Gently push each P-filter rod against its reference “stop” when any P-filter Rod screw has been loosened for any reason. See [Figure 73](#).

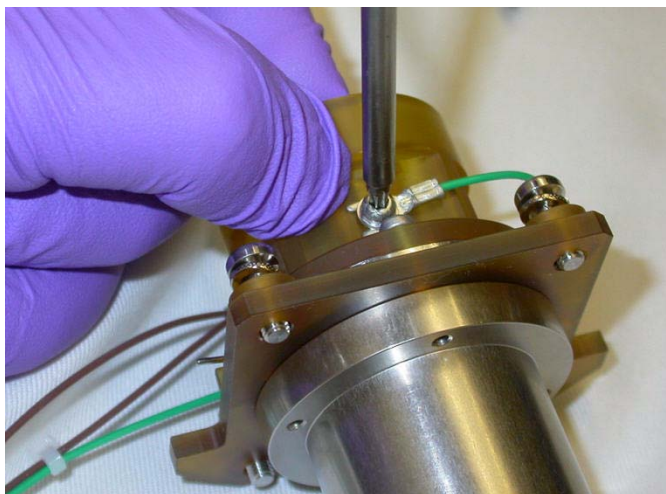

Figure 75

- 14** Loosen the two screw (p/n 0515-0372) that attach each of the two green wires to the quad P-filter holder (p/n G2597-20006) and the “vertical” P-filter quad rod. These wires are slotted so the P-Filter rods can be left in place.

- 15** Remove the green wires.

- 16** Remove the complete (p/n G2597-60802) cable harness assembly with green and brown wires. Retighten the screws if the rods will not be removed.

- 17** Gently push each P-filter rod against its reference “stop” when the screw is tightened.

2 Maintenance

To remove and clean the complete beam shaping assembly

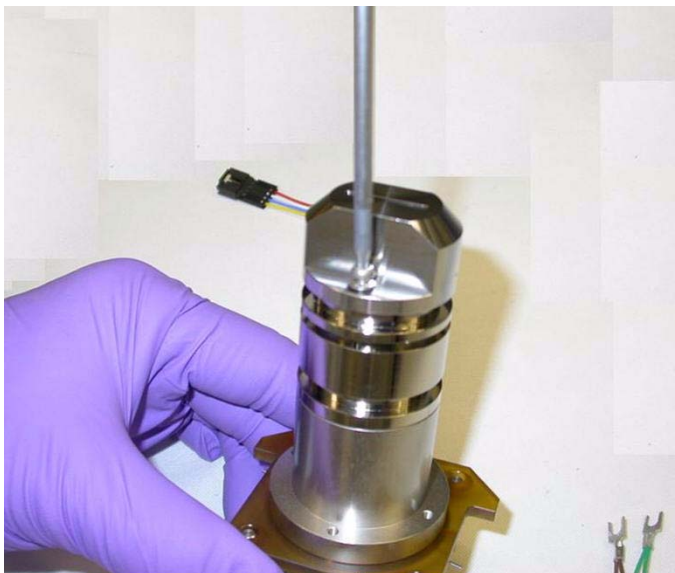

Figure 76

18 Remove the Slicer Exit (p/n G2597-20001) on the exit end of the body assembly.

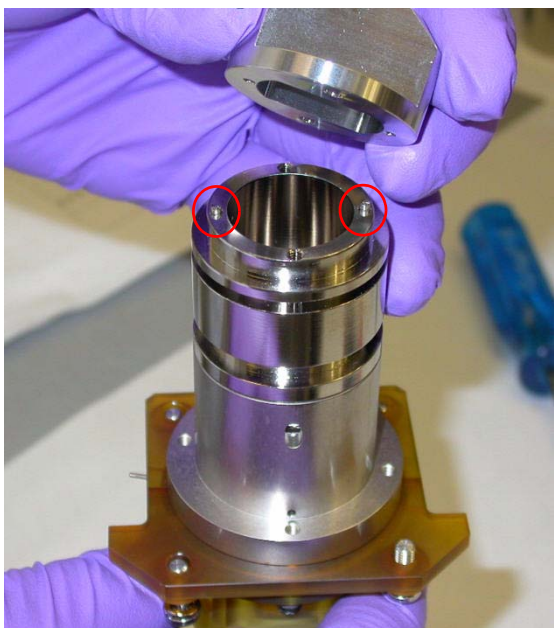

Figure 77 Aligning pins (circled)

19 Locate the two aligning pins in the barrel assembly with the two small pin holes in the slicer exit part. Remove the two screws (p/n 0515-0372) to remove the slicer exist assembly.

To remove and clean the complete beam shaping assembly

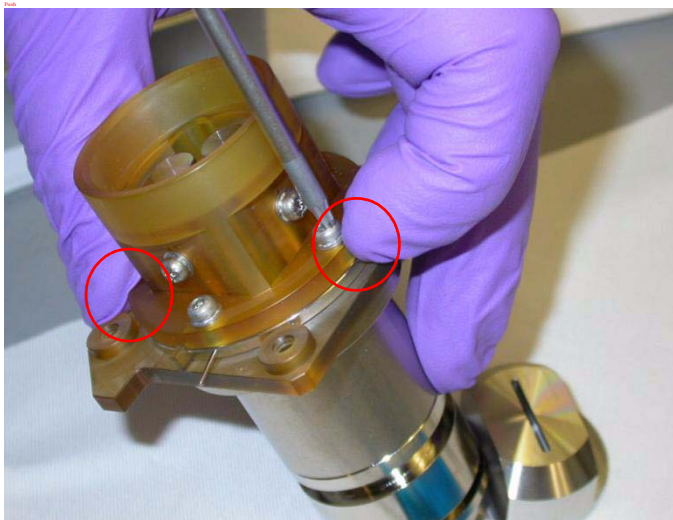

Figure 78 Push where circled.

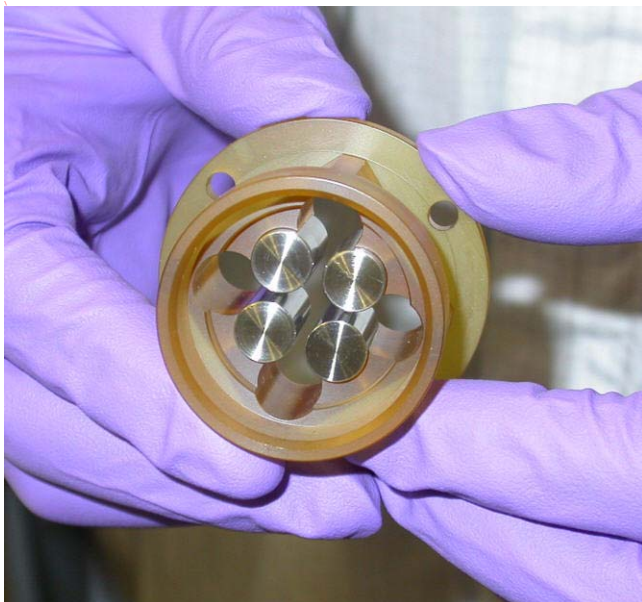

Figure 79

20 Remove the P-filter assembly from the barrel assembly. Remove the four M3 screws (p/n 0515-0375) that fasten the two sub-assemblies together.

When re-assembling, make sure to tighten the screws all the way, make sure that each slit plate is pushed towards the center to assure that it is properly seated against the reference stops/features found on the slit spacer. [Figure 78](#) shows the two slits being pressed to the center during reassembly.

[Figure 79](#) shows P-filters in the quad holder separated from the barrel assembly.

2 Maintenance

To remove and clean the complete beam shaping assembly

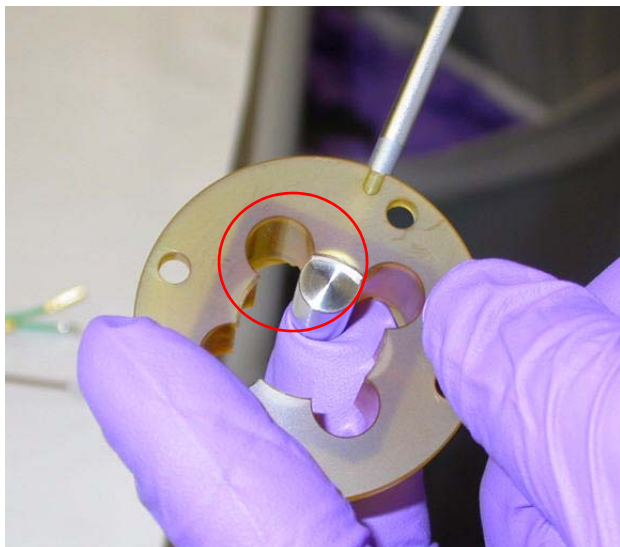

Figure 80 Reference stop (circled)

21 Gently push each P-filter rod against its reference “stop” when the screw is tightened.

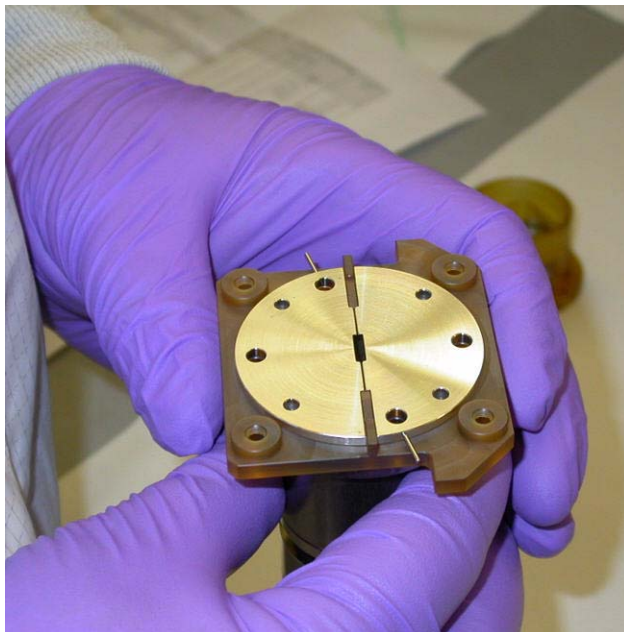

Figure 81

22 Lift and remove the 2 slit plates (p/n G2581-20080) from the slit spacer (p/n G2597-20005).

To remove and clean the complete beam shaping assembly

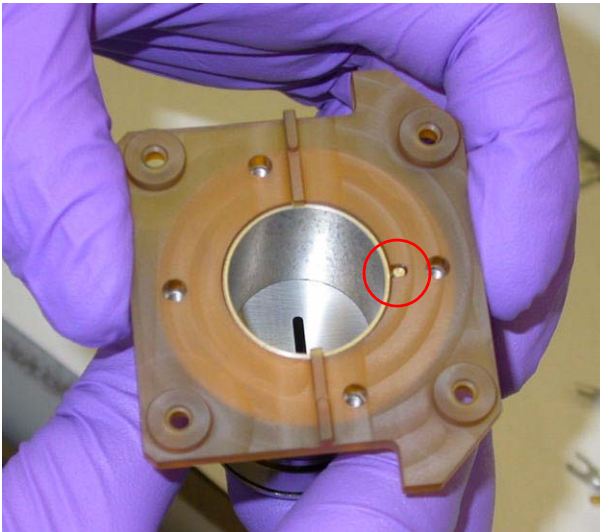

Figure 82 Pin on barrel assembly (circled). The pin is engaged in the slit spacer hole.

- 23** Remove the plastic slit spacer (p/n G2597-20005) from the slicer body assembly (p/n G2597-60139).

When you reassemble the unit, note the small pin on the barrel assembly engaged in the slit spacer's hole.

2 Maintenance

To remove and clean the complete beam shaping assembly



Figure 83 Slicer assembly part number identification.

To clean the beam-shaping slicer parts

CAUTION

This procedure is to be done by an Agilent-trained Service Engineer only. Agilent assumes no responsibility for damages if someone other than an Agilent-trained Service Engineer attempts these steps.

- 1 Clean the two slit plates, slicer exit, slicer body assembly, and the four P-filter rods with deionized water and a small amount of Alconox in a clean beaker.

Use a clean tech wipes to clean all metal surfaces.

- 2 Use deionized water to rinse all of the Alconox off of the two slit plates, slicer exit, slicer body assembly, and the four P-filter rods.

Be sure to rinse all Alconox off the parts.

- 3 Sonicate the beam-shaping slicer parts:
 - a Place the two slit plates, slicer exit, slicer body assembly, and the four P-filter rods in a clean beaker.
 - b Sonicate for 5 minutes.
 - c Pour out the isopropanol.
 - d Refill the beaker with 100% acetone.
 - e Sonicate for another 5 minutes.
 - f Pour out the acetone.
 - g Refill with 100% methanol.
 - h Sonicate for another 5 minutes.
- 4 Rinse the quad holder slit spacer and screws with methanol and wipe clean.
- 5 Reassemble the beam-shaper slicer assembly. Do in reverse order the steps used to disassemble the part.
- 6 Check the assembly for electric shorts:
 - a Use a multimeter to simultaneously touch the left pin coming off the slit plate and the body of the barrel assembly.
 - b Check that the multimeter displays “OL”.
 - c Repeat this measurement on the right pin coming off the second slit plate.

2 Maintenance

To clean the beam-shaping slicer parts

The beam-shaper assembly (G2597-60200) is now clean and ready to re-install into the manifold.

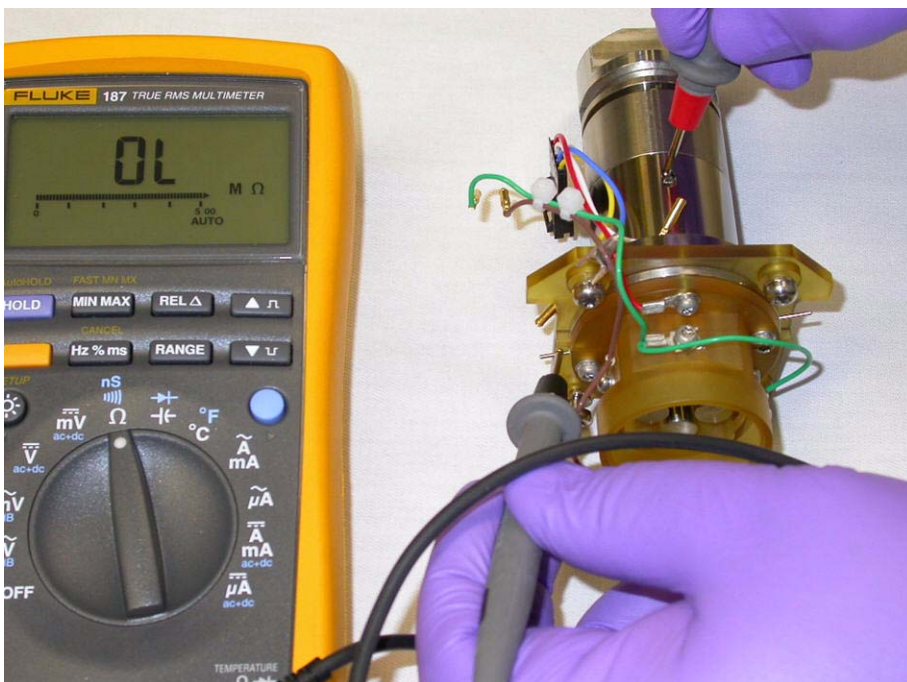

Figure 84 Testing the beam-shaping assembly with a multimeter.

To clean the beam-shaping slicer parts

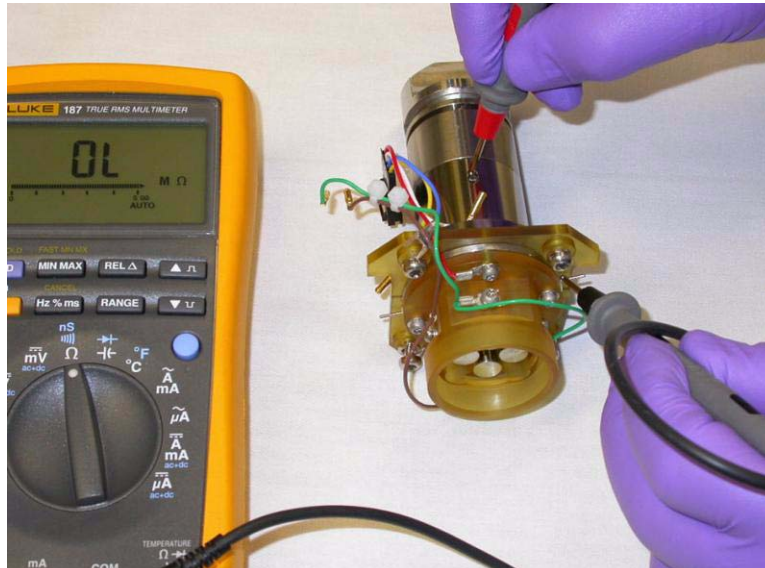

Figure 85

- 7 Reinstall the beam-shaping slicer assembly into the manifold.

Do in reverse order the steps used to remove the beam-shaping slicer assembly from the manifold.

- 8 Reinstall the ion optics into the manifold.

Make sure to keep the ion optics and beam-shaper slicer assembly in the same physical orientation in the vacuum manifold as they were when they were removed.

- 9 Make sure all wiring connections are correct.

- 10 Do in reverse order the steps used to vent and remove the ion topics and beam slicer to prepare the instrument to pump down.

- 11 Turn on the instrument at the front power switch.

The instrument automatically starts the pump down process.

- 12 After the instrument starts up, start the Diagnostics program on the PC.

Connect the instrument from the Diagnostics pull-down menu in the Diagnostics program.

2 Maintenance

To clean the beam-shaping slicer parts

- 13** In the **Parameters** tab, check the rough pump vacuum and turbo speed to see the progress of the pump down.
- 14** Do a high voltage conditioning for a 2-Hour cycle (optics service). The high vacuum condition starts after the high vacuum has reached 2.0×10^{-6} torr.
- 15** When the high voltage conditioning is done and the vacuum is acceptable (5.0×10^{-7} torr), tune the instrument:
 - Do initial positive and negative tune in 2 GHz Extended Dynamic range.
 - Do standard positive and negative polarity switching tunes.

Vacuum System

This section lists procedures to maintain the vacuum system of the instrument. They should be performed according to the maintenance schedule or as indicated by instrument symptoms.

To check the rough pump fluid level

Check the level and color of the pump fluid weekly.

- Check the fluid level in the window of the rough pump. The fluid level should be between the marks for Max and Min (see [Figure 86](#)).
- Check that the color of the pump fluid is clear or almost clear with few suspended particles.
- If the pump fluid is dark or full of suspended particles, replace it.

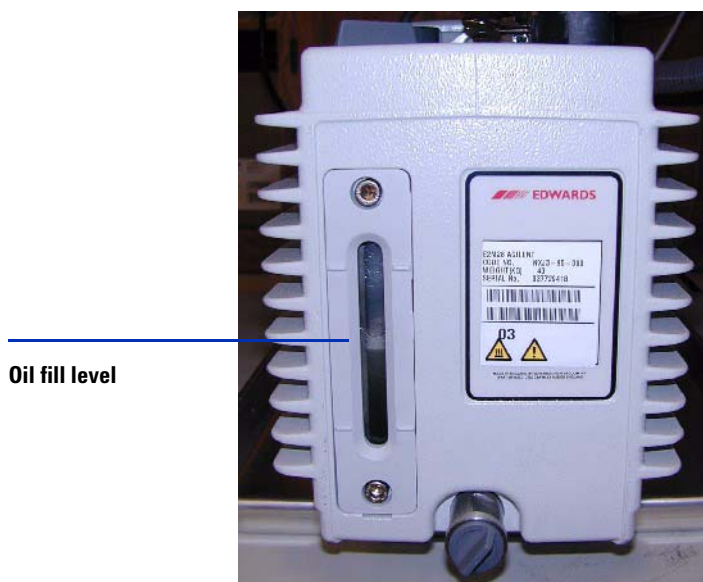

Figure 86 Fluid level window on the rough pump

2 Maintenance

To check the rough pump fluid level

CAUTION

Never add or replace the rough pump fluid while the pump is on.

NOTE

Record this procedure in the Maintenance Logbook.

To check the oil mist filter

Check the oil mist filter **weekly**.

- Check the oil mist filter.

Check for any damage and if pump fluid has been collected in it.

- Check the oil mist filter for damage.

If the oil mist filter is damaged, replace it.

- Check whether oil has collected in the bottom of the oil mist filter.

If oil is found in the oil mist filter, open the gas ballast valve counter-clockwise just enough to return the condensed oil back to the pump.

Close the gas ballast valve clockwise.

NOTE

When you close the ballast valve, you increase the efficiency of the pump. However, you lose oil to the mist filter if you don't recycle. Check the status of your oil mist filter at least once per week to ensure that it does not fill with oil. If you lose too much oil in the rough pump, the vacuum will not be maintained, and the TOF will vent.

2 Maintenance

To add rough pump fluid

To add rough pump fluid

Add pump fluid when the pump fluid level is low. Before you begin, make sure you have:

- Funnel
- Gloves, chemical resistant, clean, lint free (p/n 9300-1751)
- Rough pump fluid (Inland 45 oil, p/n 6040-0834)

CAUTION

Wear chemical-resistant gloves and safety glasses (goggles)

WARNING

Never add pump fluid while the pump is on.

WARNING

The fill cap and pump may be dangerously hot. Check that the fill cup and pump are cool before you touch them.

CAUTION

Use only Edwards rough pump fluid (Inland 45 oil, p/n 6040-0834). Any other fluids can substantially reduce pump life and invalidates the pump warranty.

- 1 Vent and turn off the instrument.
See “[To shut down the instrument](#)” on page 17.
- 2 Unplug the instrument power cord from the electrical outlet.
Leave the power cord unplugged while you do this procedure.
- 3 Remove the fill cap on the rough pump (see [Figure 87](#)).
- 4 Add new pump fluid until the fluid level is near, but not over the maximum mark beside the fluid level window (see [Figure 87](#)).
- 5 Reinstall the fill cap.
- 6 Wipe off all excess oil around and underneath of the pump.
- 7 Reconnect the power cord.

8 Start up the instrument.

See “To start the system in Standby mode” on page 12.

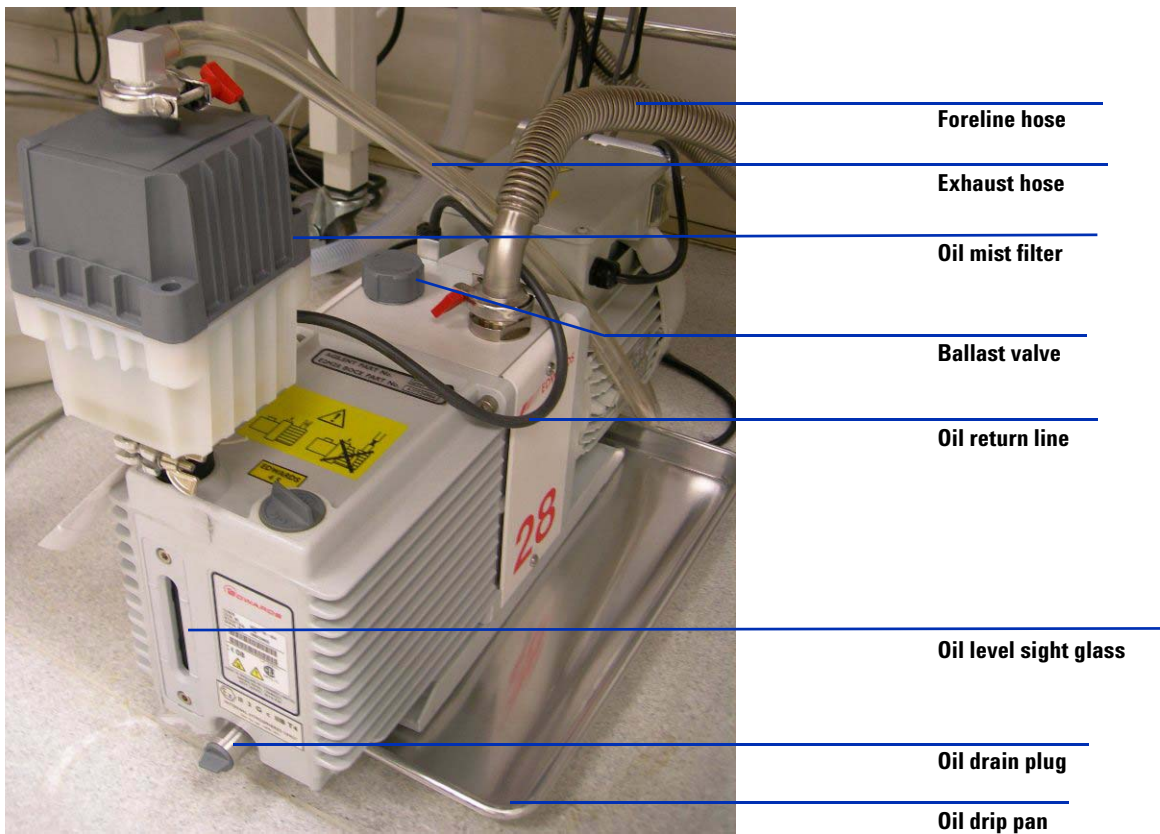

Figure 87 Rough pump.

2 Maintenance

To replace the rough pump fluid

To replace the rough pump fluid

Replace the pump fluid every six months. Replace it sooner if the fluid appears dark or cloudy.

Before you begin, make sure you have:

- Container for catching old pump fluid
- Funnel
- Gloves, chemical resistant, clean, lint free (p/n 9300-1751)
- Rough pump fluid (Inland 45 oil, p/n 6040-0834)
- Screwdriver, flat-bladed, large (p/n 8710-1029)

CAUTION

Wear chemical-resistant gloves and safety glasses (goggles)

WARNING

Never add pump fluid while the pump is on.

WARNING

The fill cap and pump may be dangerously hot. Check that the fill cap and pump are cool before you touch them.

WARNING

Do not touch the fluid. The residue from some samples are toxic. Properly dispose of the fluid.

CAUTION

Use only Edwards rough pump fluid (Inland 45 oil, p/n 6040-0834). Any other fluids can substantially reduce pump life and invalidates the pump warranty.

1 Turn off the instrument.

See [“To shut down the instrument”](#) on page 17.

- 2 Unplug the power cord from the instrument

Leave the power cord unplugged while performing this procedure.

- 3 Place a container under the drain plug of the rough pump (see [Figure 87](#) on page 139).
- 4 Remove first the fill cap (see [Figure 87](#) on page 139), then open the drain plug.

Allow the fluid to drain completely.

- 5 Reinstall the drain plug.
- 6 Pour in new pump fluid until the fluid level is near, but not above the maximum mark beside the fluid level window (see [Figure 87](#) on page 139).
- 7 Reinstall the fill cap.
- 8 Reconnect the power cord.
- 9 Start up the instrument.

See “[To start the system in Standby mode](#)” on page 12.

- 10 After 30 minutes pump down, inspect the pump for leak.

Inspect for leak after overnight pump down.

2 Maintenance

To replace the fuses

To replace the fuses

- When required** As necessary.
- Tools required** Flat Blade Screw Driver
- Parts required**
- 8 Amp Fuse 2110-0969
 - 12 Amp Fuse 2110-1398

WARNING

Never replace the fuses with the instrument plugged into the power outlet. The instrument will immediately begin to pump down.

- 1 Unplug the instrument power cord from the power outlet.



Figure 88 Disconnect the instrument power cable.

- 2 Using a flat blade screw driver, remove the fuse holder of the blown fuse



Figure 89 AC Board fuses

- 3** Replace with the appropriate fuse. See [“Replaceable Fuses”](#) on page 147.
- 4** Reinstall the fuse holder.
- 5** Plug in the instrument.
- 6** Push the front power switch to start an automatic pump down sequence.

2 Maintenance

To replace the fuses



3 Reference

Safety [146](#)

Environmental Conditions [147](#)

Replaceable Fuses [147](#)

This chapter contains safety and other reference information for your 6224/6230 Series TOF LC/MS System.



Safety

If the 6224/6230 Series TOF LC/MS System is used in a manner not specified by Agilent Technologies, the protections provided by the instrument may be impaired.



Caution,
Risk of danger,
Consult documentation



Caution,
Risk of Electric Shock



Caution,
Hot Surfaces,
Risk of Burns

Environmental Conditions

Equipment Class	Class 1 Laboratory Equipment
Pollution Degree	2
Installation Category	II
Environment	Indoor Use
Altitude	Not to exceed 3000 m
Electrical supply	200 - 240 V AC, 50/60 Hz, 2500 VA
Mains supply voltage	Fluctuations not to exceed 10% of nominal supply voltage
Operating Temperature	15 to 35°C (59 to 95°F)
Humidity	< 85% RH at 35°C

Replaceable Fuses

8A	2110-0969
12A	2110-1398

3 Reference

Replaceable Fuses

www.agilent.com

In This Book

This book contains tasks to help you maintain your 6224/6230 Series TOF LC/MS System.

© Agilent Technologies, Inc. 2009

Printed in USA
First Edition, March 2009



G2597-90005



Agilent Technologies